

Doc. Number:

- Tentative Specification
- Preliminary Specification
- Approval Specification

MODEL NO.: BF097XN

Customer:	
APPROVED BY	SIGNATURE
_____	_____
Note	

Please return 1 copy for your confirmation with your signature and comments.	

Approved By	Checked By	Prepared By
		Annie Lu

CONTENTS

1. GENERAL DESCRIPTION	3
1.1 OVERVIEW.....	3
1.2 GENERAL SPECIFICATION.....	3
2. MECHANICAL SPECIFICATION.....	3
2.1 CONNECTOR TYPE.....	3
3. ABSOLUTE MAXIMUM RATINGS	3
3.1 ABSOLUTE RATINGS OF ENVIRONMENT	3
3.2 ELECTRICAL ABSOLUTE RATINGS.....	3
3.2.1 TFT LCD MODULE	3
4. ELECTRICAL SPECIFICATION	3
4.1 FUNCTION BLOCK DIAGRAM.....	3
4.2. INTERFACE CONNECTION.....	3
4.3 ELECTRICAL CHARACTERISTICS	3
4.3.1 LCD ELECTRICAL SPECIFICATION.....	3
4.3.2 BACKLIGHT UNIT	3
4.4 LVDS INPUT SIGNAL TIMING SPECIFICATION.....	3
4.4.1 LVDS DC SPECIFICATION	3
4.4.2 LVDS DATA FORMAT	3
4.4.3 COLOR DATA INPUT ASSIGNMENT	3
4.5 DISPLAY TIMING SPECIFICATION.....	3
4.6 POWER ON/OFF SEQUENCE	3
5. OPTICAL CHARACTERISTICS	3
5.1 TEST CONDITION.....	3
5.2 OPTICAL SPECIFICATION.....	3
6. RELIABILITY TEST ITEM	3
7. PACKING.....	3
7.1 MODULE LABEL.....	3
7.2 CARTON.....	3
7.3 PALLET.....	3
8. PRECAUTIONS	3
8.1 HANDLING PRECAUTION	3
8.2 STORAGE PRECAUTION	3
8.3 OPERATION PRECAUTION.....	3
Appendix. OUTLINE DRAWING	35

REVISION HISTORY

Version	Date	Page	Description
0.0	Apr. 18, 2011	All	Spec Ver.0.0 was first issued.
0.1	May 3, 2011	4, Appendix	Modified module thickness (with PCBA side).
0.2	Aug 5, 2011	15, 20	Modification color chromaticity Modification module label

1. GENERAL DESCRIPTION

1.1 OVERVIEW

BF097XN is a 9.7" (9.676" diagonal) TFT Liquid Crystal Display module with LED Backlight unit and 30 pins LVDS interface. This module supports 1024 x 768 XGA mode and can display 262,144 colors.

1.2 GENERAL SPECIFICATIONS

Item	Specification	Unit	Note
Screen Size	9.676" diagonal		
Driver Element	a-Si TFT active matrix	-	-
Pixel Number	1024x R.G.B. x 768	pixel	-
Pixel Pitch	0.192 (V) x 0.192 (H)	mm	-
Pixel Arrangement	RGB vertical stripe	-	-
Display Colors	262,144	color	-
Transmissive Mode	Normally black	-	-
Surface Treatment	Hard coating (3H), Glare	-	-
Luminance, White	420 Typ.	Cd/m2	
Power Consumption	Total 3.14 W (Max.) @ cell 0.98 W (Max.), LED BL 2.16W (Max.)		(1)

Note (1) The specified power consumption (without converter efficiency) is under the conditions at VCCS = 3.3 V, $f_v = 60$ Hz, $I_{LED} = 20$ mA and $T_a = 25 \pm 2$ °C, whereas white pattern is displayed.

2. MECHANICAL SPECIFICATIONS

Item		Min.	Typ.	Max.	Unit	Note
Module Size	Horizontal (H)	210.01	210.21	210.41	mm	(1)
	Vertical (V)	164.05	164.25	164.45	mm	
	Thickness (T)	W/O PCBA		2.52	2.85	
PCBA Side		-		5.25	mm	
Active Area	Horizontal	-	196.608	-	mm	
	Vertical	-	147.456	-	mm	
Weight		-		145	g	

Note (1) Please refer to the attached drawings for more information of front and back outline dimensions.

2.1 CONNECTOR TYPE

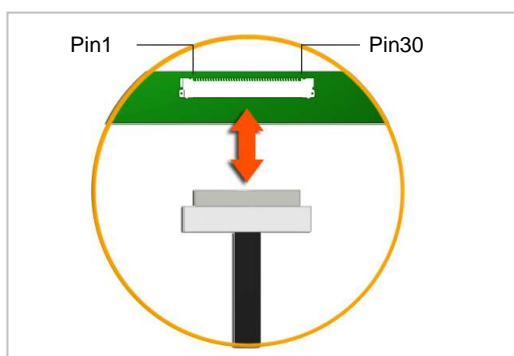

Connector Part No.: 20525-030E-02/I-PEX or equivalent

User's connector Part No: 20523-030T-01/I-PEX or equivalent

3. ABSOLUTE MAXIMUM RATINGS

3.1 ABSOLUTE RATINGS OF ENVIRONMENT

Item	Symbol	Value		Unit	Note
		Min.	Max.		
Storage Temperature	T _{ST}	-25	+65	°C	(1)
Operating Ambient Temperature	T _{OP}	0	+50	°C	(1), (2)

Note (1) (a) 90 %RH Max. (Ta ≤ 40 °C).

(b) Wet-bulb temperature should be 39 °C Max. (Ta > 40 °C).

(c) No condensation.

Note (2) The temperature of panel surface should be 0 °C min. and 50 °C max.

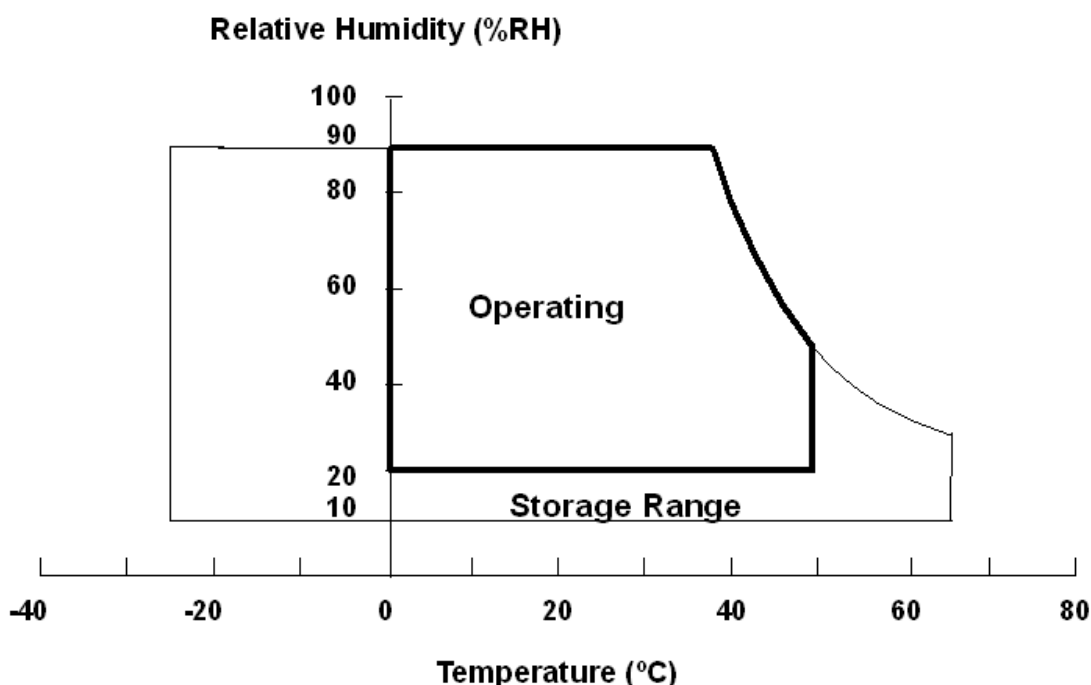

3.2 ELECTRICAL ABSOLUTE RATINGS

3.2.1 TFT LCD MODULE

Item	Symbol	Value		Unit	Note
		Min.	Max.		
Power Supply Voltage	V _{CCS}	-0.3	+4.0	V	(1)
Logic Input Voltage	V _{IN}	-0.3	V _{CCS} +0.3	V	

Note (1) Stress beyond those listed in above “ELECTRICAL ABSOLUTE RATINGS” may cause permanent damage to the device. Normal operation should be restricted to the conditions described in “ELECTRICAL CHARACTERISTICS”.

4. ELECTRICAL SPECIFICATION

4.1 FUNCTION BLOCK DIAGRAM

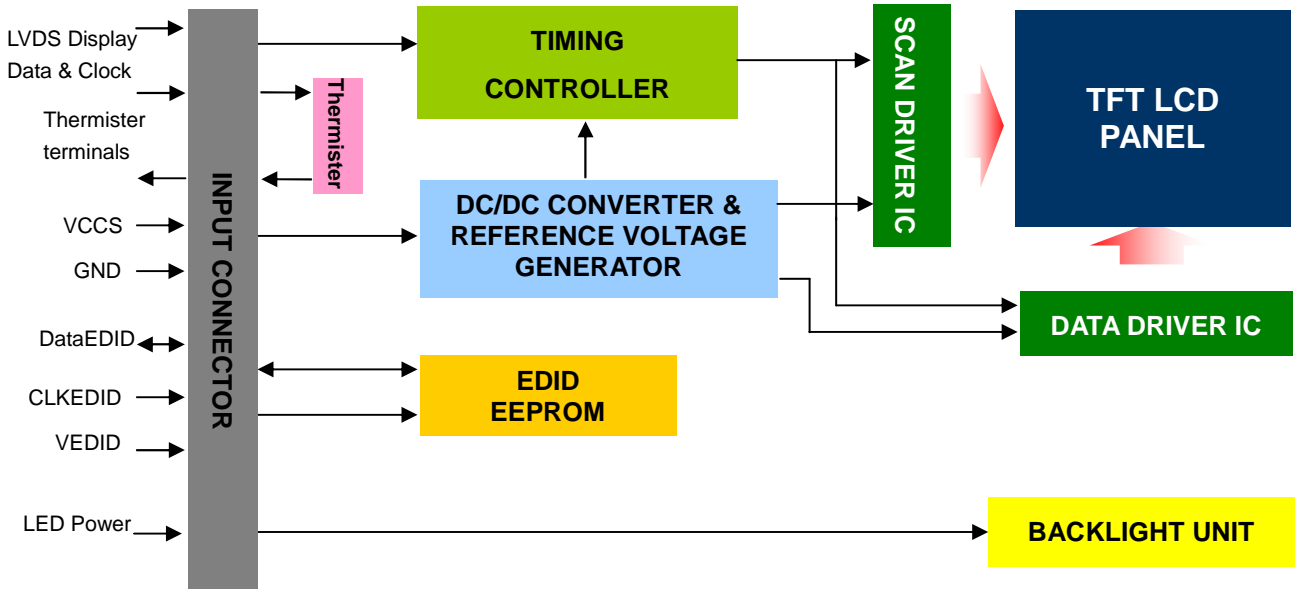

4.2. INTERFACE CONNECTIONS

PIN ASSIGNMENT

Pin	Symbol	Description	Remark
1	VSS	Ground	
2	VCCS	Power Supply (3.3V typ.)	
3	VCCS	Power Supply (3.3V typ.)	
4	VEDID	DDC 3.3V power	
5	Therm1	Thermister terminal1	
6	CLKEDID	DDC clock	
7	DATAEDID	DDC data	
8	Rxin0-	LVDS differential data input	R0-R5, G0 (1)
9	Rxin0+	LVDS differential data input	
10	VSS	Ground	
11	Rxin1-	LVDS differential data input	G1~G5, B0, B1 (1)
12	Rxin1+	LVDS differential data input	
13	VSS	Ground	
14	Rxin2-	LVDS Differential Data Input	B2-B5,HS,VS, DE (1)
15	Rxin2+	LVDS Differential Data Input	
16	VSS	Ground	
17	RxCLK-	LVDS differential clock input	LVDS CLK
18	RxCLK+	LVDS differential clock input	
19	VSS	Ground	
20	NC	No Connection (Reserve)	
21	Vdc	LED Annold (Positive)	
22	Vdc	LED Annold (Positive)	
23	NC	No Connection (Reserve)	

24	Vdc1	LED Cathode1 (Negative)	
25	Vdc2	LED Cathode2 (Negative)	
26	Vdc3	LED Cathode3 (Negative)	
27	Vdc4	LED Cathode4 (Negative)	
28	Vdc5	LED Cathode5 (Negative)	
29	Vdc6	LED Cathode6 (Negative)	
30	Therm2	Thermister terminal2	

Note (1) The first pixel is odd as shown in the following figure.

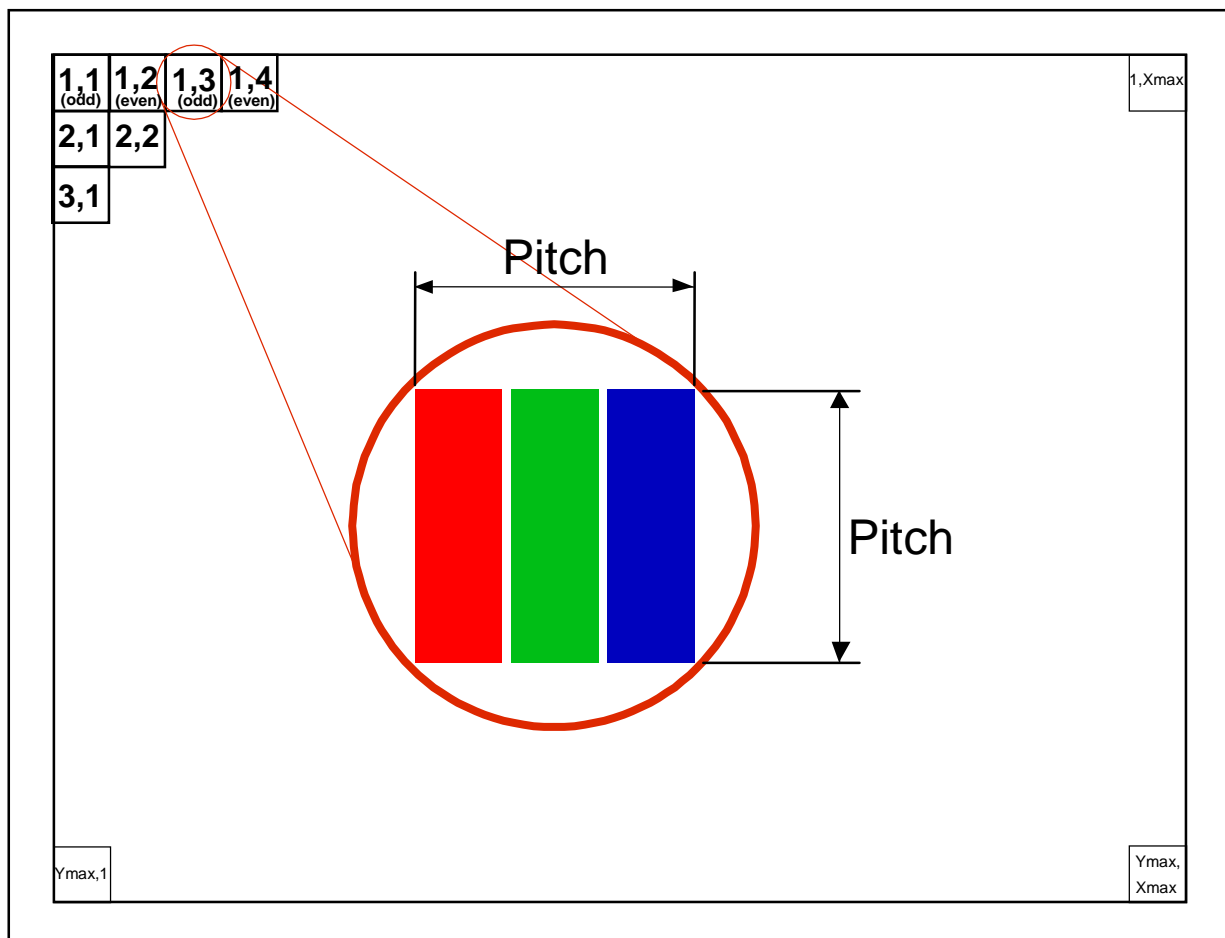

4.3 ELECTRICAL CHARACTERISTICS

4.3.1 LCD ELECTRICAL SPECIFICATION

Parameter	Symbol	Value			Unit	Note	
		Min.	Typ.	Max.			
Power Supply Voltage	VCCS	3.0	3.3	3.6	V	(1)	
Ripple Voltage	V _{RP}	-	50	100	mV	(1)	
Inrush Current	I _{RUSH}	-	-	1.5	A	(1),(2)	
Power Supply Current	Mosaic	I _{CC}	-	227	250	mA	(3)a
	White		-	297	327	mA	(3)b

Note (1) The ambient temperature is $T_a = 25 \pm 2 \text{ }^\circ\text{C}$.

Note (2) I_{RUSH}: the maximum current when VCCS is rising

I_{IS}: the maximum current of the first 100ms after power-on

Measurement Conditions: Shown as the following figure. Test pattern: white.

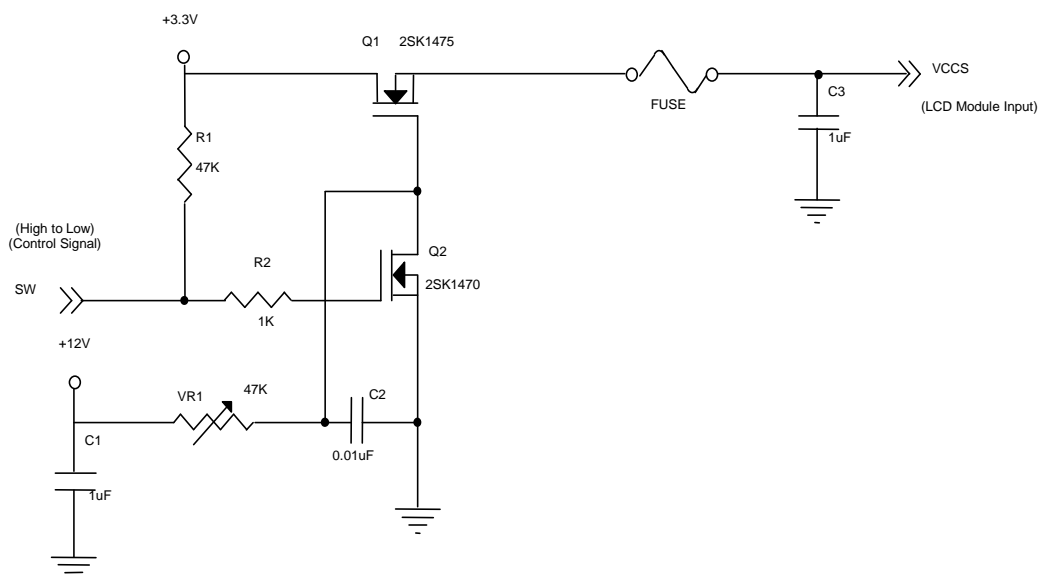

VCCS rising time is 0.5ms

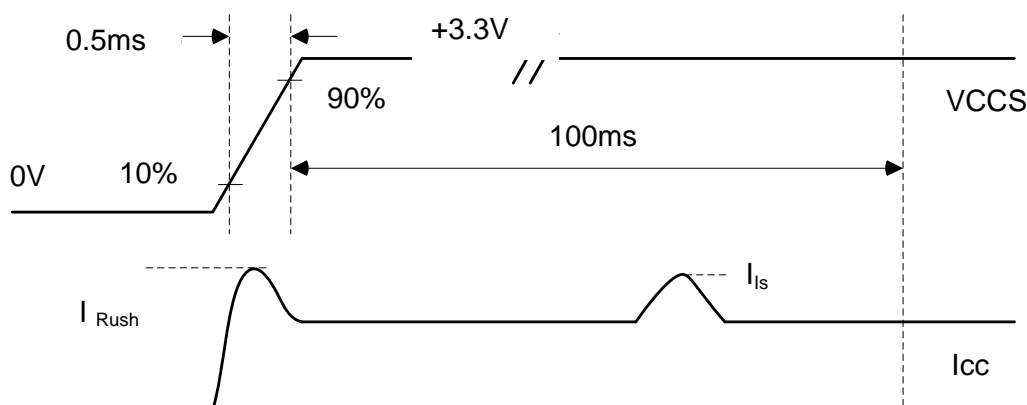

Note (3) The specified power supply current is under the conditions at $V_{CCS} = 3.3\text{ V}$, $T_a = 25 \pm 2\text{ }^\circ\text{C}$, DC Current and $f_v = 60\text{ Hz}$ ($f_{CLK} = 100\text{MHz}$), whereas a power dissipation check pattern below is displayed.

a. Mosaic Pattern

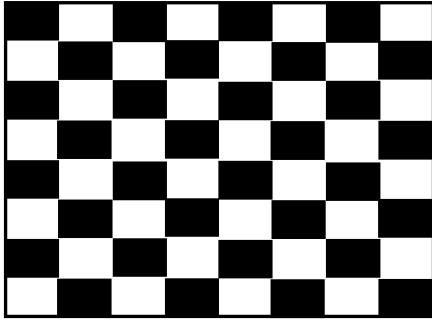

Active Area

b. White Pattern

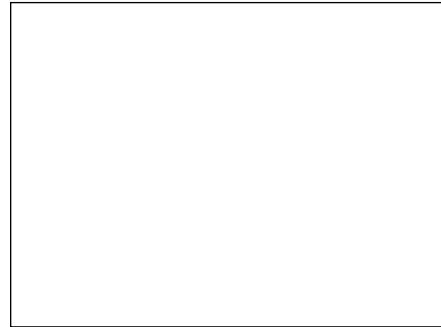

Active Area

4.3.2 BACKLIGHT UNIT (6 Strings, 6 LED per string)

Ta = 25 ± 2 °C

Parameter	Symbol	Value			Unit	Note
		Min.	Typ.	Max.		
Number of LEDs	NLED	-	36	-	pc	
Forward Voltage	V _F	2.6	2.9	3.0	V	I _F = 20mA
Forward Current	I _F	-	20	-	mA	(1)
Power Consumption	PL	1.88	2.09	2.16	W	(2)
LED Life Time	L _{BL}	15,000	-	-	Hrs	(3)

Note (1) For better LED light bar driving quality, it is recommended to utilize the adaptive boost converter with current balancing function to drive LED light-bar.

Note (2) $P_L = V_F \times I_F \times N_{LED}$ (Without LED converter transfer efficiency)

Note (3) The life time of LED is defined as the time when it continues to operate under the conditions at Ta = 25 ± 2 °C and I_L = 20 mA (Per EA) until the brightness becomes ≤ 50% of its original value.

4.4 LVDS INPUT SIGNAL TIMING SPECIFICATION

4.4.1 LVDS DC SPECIFICATION

Parameter	Symbol	Value			Unit	Note
		Min.	Typ.	Max.		
LVDS Differential Input High Threshold	$V_{TH(LVDS)}$	-	-	+100	mV	(1), $V_{CM}=1.2V$
LVDS Differential Input Low Threshold	$V_{TL(LVDS)}$	-100	-	-	mV	(1) $V_{CM}=1.2V$
LVDS Common Mode Voltage	V_{CM}	1.125	1.200	1.375	V	(1)
LVDS Differential Input Voltage	$ V_{ID} $	100	-	600	mV	(1)
LVDS Terminating Resistor	R_T	90	100	110	Ohm	-

Note (1) The parameters of LVDS signals are defined as the following figures.

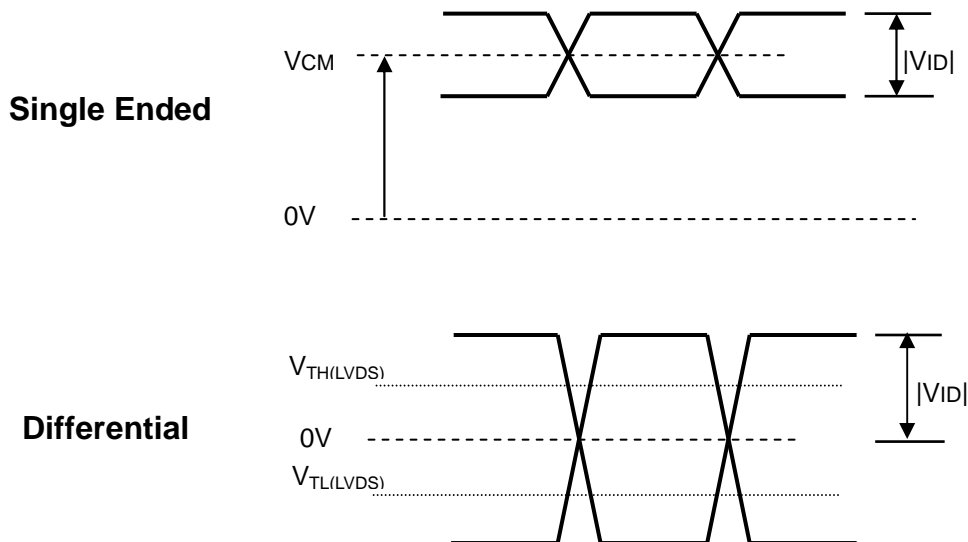

4.4.2 LVDS DATA FORMAT

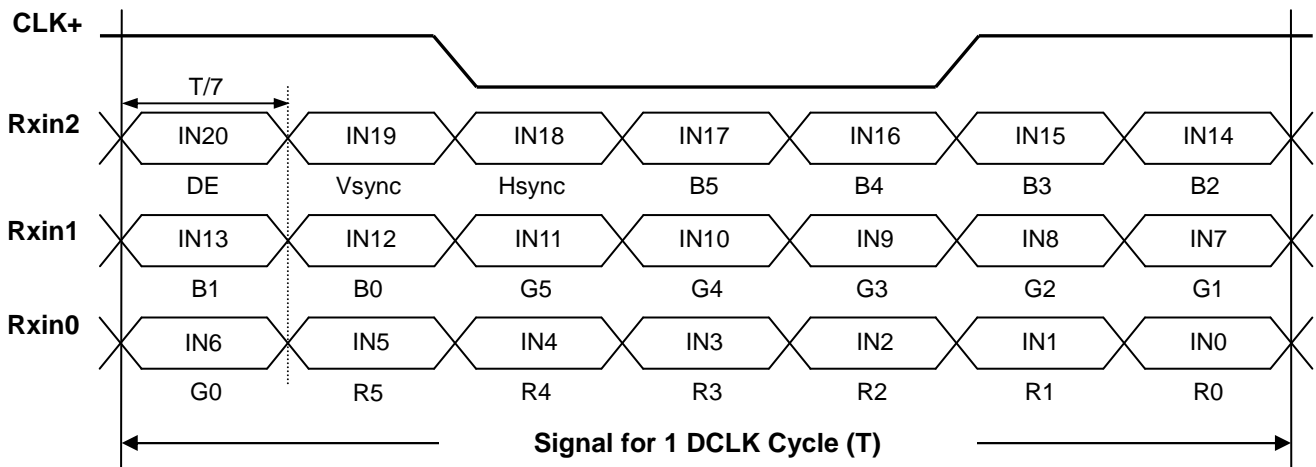

4.4.3 COLOR DATA INPUT ASSIGNMENT

The brightness of each primary color (red, green and blue) is based on the 6-bit gray scale data input for the color. The higher the binary input the brighter the color. The table below provides the assignment of color versus data input.

Color		Data Signal																	
		Red						Green						Blue					
		R5	R4	R3	R2	R1	R0	G5	G4	G3	G2	G1	G0	B5	B4	B3	B2	B1	B0
Basic Colors	Black	0	0	0	0	0	0	0	0	0	0	0	0	0	0	0	0	0	0
	Red	1	1	1	1	1	1	0	0	0	0	0	0	0	0	0	0	0	0
	Green	0	0	0	0	0	0	1	1	1	1	1	1	0	0	0	0	0	0
	Blue	0	0	0	0	0	0	0	0	0	0	0	0	1	1	1	1	1	1
	Cyan	0	0	0	0	0	0	1	1	1	1	1	1	1	1	1	1	1	1
	Magenta	1	1	1	1	1	1	0	0	0	0	0	0	1	1	1	1	1	1
	Yellow	1	1	1	1	1	1	1	1	1	1	1	1	0	0	0	0	0	0
	White	1	1	1	1	1	1	1	1	1	1	1	1	1	1	1	1	1	1
Gray Scale Of Red	Red(0)/Dark	0	0	0	0	0	0	0	0	0	0	0	0	0	0	0	0	0	
	Red(1)	0	0	0	0	0	1	0	0	0	0	0	0	0	0	0	0	0	
	Red(2)	0	0	0	0	1	0	0	0	0	0	0	0	0	0	0	0	0	
	:	:	:	:	:	:	:	:	:	:	:	:	:	:	:	:	:	:	
	:	:	:	:	:	:	:	:	:	:	:	:	:	:	:	:	:	:	
	Red(61)	1	1	1	1	0	1	0	0	0	0	0	0	0	0	0	0	0	
	Red(62)	1	1	1	1	1	0	0	0	0	0	0	0	0	0	0	0	0	
	Red(63)	1	1	1	1	1	1	0	0	0	0	0	0	0	0	0	0	0	
Gray Scale Of Green	Green(0)/Dark	0	0	0	0	0	0	0	0	0	0	0	0	0	0	0	0	0	
	Green(1)	0	0	0	0	0	0	0	0	0	0	0	1	0	0	0	0	0	
	Green(2)	0	0	0	0	0	0	0	0	0	0	1	0	0	0	0	0	0	
	:	:	:	:	:	:	:	:	:	:	:	:	:	:	:	:	:	:	
	:	:	:	:	:	:	:	:	:	:	:	:	:	:	:	:	:	:	
	Green(61)	0	0	0	0	0	0	1	1	1	1	0	1	0	0	0	0	0	
	Green(62)	0	0	0	0	0	0	1	1	1	1	1	0	0	0	0	0	0	
	Green(63)	0	0	0	0	0	0	1	1	1	1	1	1	0	0	0	0	0	
Gray Scale Of Blue	Blue(0)/Dark	0	0	0	0	0	0	0	0	0	0	0	0	0	0	0	0	0	
	Blue(1)	0	0	0	0	0	0	0	0	0	0	0	0	0	0	0	0	1	
	Blue(2)	0	0	0	0	0	0	0	0	0	0	0	0	0	0	0	1	0	
	:	:	:	:	:	:	:	:	:	:	:	:	:	:	:	:	:	:	
	:	:	:	:	:	:	:	:	:	:	:	:	:	:	:	:	:	:	
	Blue(61)	0	0	0	0	0	0	0	0	0	0	0	0	1	1	1	1	0	
	Blue(62)	0	0	0	0	0	0	0	0	0	0	0	0	1	1	1	1	0	
	Blue(63)	0	0	0	0	0	0	0	0	0	0	0	0	1	1	1	1	1	

Note (1) 0: Low Level Voltage, 1: High Level Voltage

4.5 DISPLAY TIMING SPECIFICATION

The input signal timing specifications shown as the following table and timing diagram.

Signal	Item	Symbol	Min.	Typ.	Max.	Unit	Note
DCLK	Frequency	1/Tc	-	100	-	MHz	-
DE	Vertical Total Time	TV	-	800	-	TH	-
	Vertical Active Display Period	TVD	-	768	-	TH	-
	Vertical Active Blanking Period	TVB	-	32	-	TH	-
	Horizontal Total Time	TH	-	2084	-	Tc	-
	Horizontal Active Display Period	THD	-	1024	-	Tc	-
	Horizontal Active Blanking Period	THB	-	1060	-	Tc	-

Note (1) Because this module is operated by DE only mode, Hsync and Vsync are ignored.

INPUT SIGNAL TIMING DIAGRAM

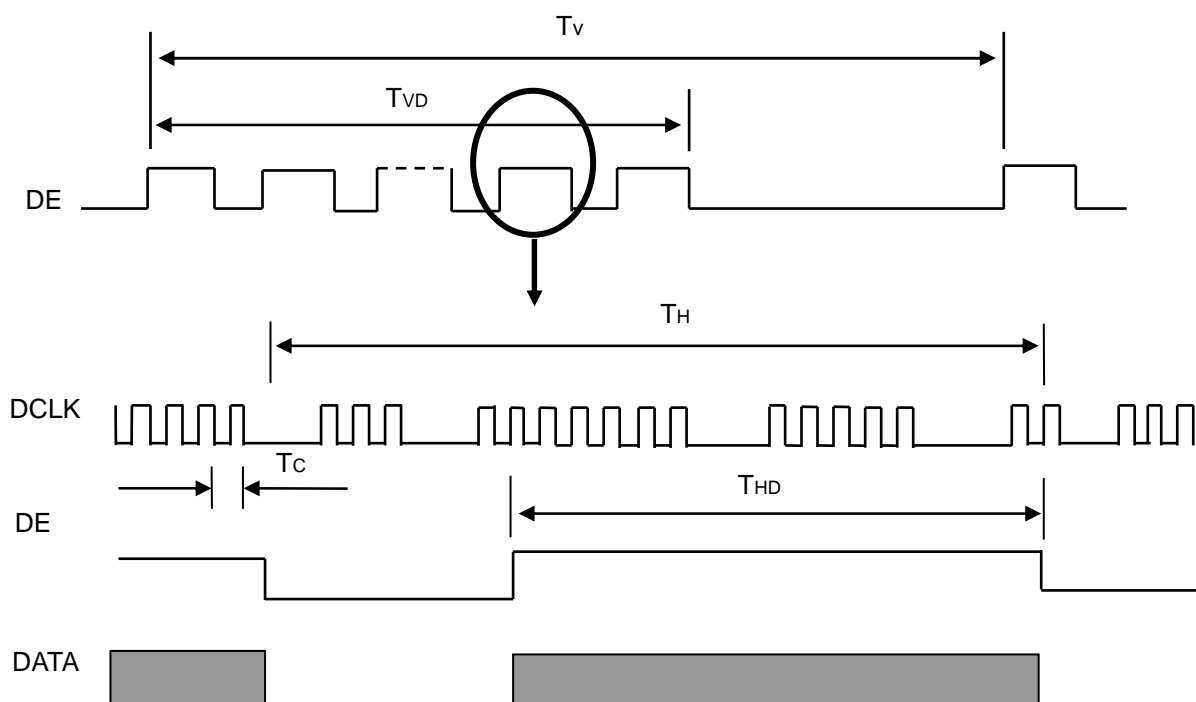

4.6 POWER ON/OFF SEQUENCE

The power sequence specifications are shown as the following table and diagram.

Symbol	Value			Unit	Note
	Min.	Typ.	Max.		
T1	0.5	-	10	ms	
T2	0	20	50	ms	
T3	70	250	-	ms	
T4	200	250	-	ms	
T5	0.5	20	50	ms	
T6	0	-	20	ms	
T7	200	-	-	ms	

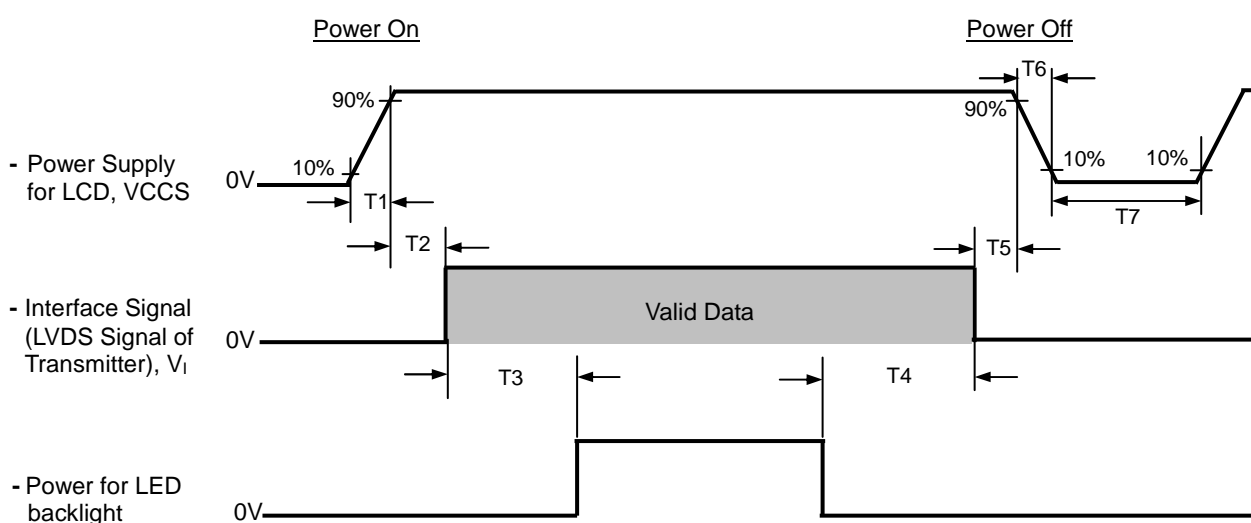

Note (1) Please don't plug or unplug the interface cable when system is turned on.

Note (2) Please avoid floating state of the interface signal during signal invalid period.

Note (3) It is recommended that the backlight power must be turned on after the power supply for LCD and the interface signal is valid.

5. OPTICAL CHARACTERISTICS

5.1 TEST CONDITIONS

Item	Symbol	Value	Unit
Ambient Temperature	Ta	25±2	°C
Ambient Humidity	Ha	50±10	%RH
Supply Voltage	V _{CCS}	3.3	V
Input Signal	According to typical value in "3. ELECTRICAL CHARACTERISTICS"		
LED Light Bar Input Current	I _L	20	mA

The measurement methods of optical characteristics are shown in Section 5.2. The following items should be measured under the test conditions described in Section 5.1 and stable environment shown in Note (5).

5.2 OPTICAL SPECIFICATIONS

Parameter	Symbol	Condition	Min.	Typ.	Max.	Unit	Note
Contrast ratio	CR	Optimal	700	900	--	--	1,2,3
Response (rise + fall time)	$\tau_{on} + \tau_{off}$	$\theta = 0^\circ$, Ta=30°C	--	20	24	ms	1,2,3
Max Gray to Gray Response time	τ_{G2G}	$\theta = 0^\circ$, Ta=30°C	--	20	24	ms	1,2,3
Luminance	Y	I _{LED} =20mA	380	420	--	cd/m ²	1,2,4
White Chromaticity	Wx	CIE 1931	0.275	0.310	0.345	--	1,2,3
	Wy		0.292	0.327	0.362	--	1,2,3
Red Chromaticity	Rx		0.57	0.605	0.64	--	1,2,3
	Ry		0.31	0.345	0.38	--	1,2,3
Green Chromaticity	Gx		0.283	0.318	0.353	--	1,2,3
	Gy		0.537	0.572	0.607	--	1,2,3
Blue Chromaticity	Bx		0.115	0.150	0.185	--	1,2,3
	By		0.081	0.116	0.151	--	1,2,3
Iso-Contrast Viewing Angle	θ	CR ≥ 100 Horizontal	75	85	--	Degrees	1,2,3
	θ	CR ≥ 10 Horizontal and Vertical Directions	85	89	--	Degrees	1,2,3
	θ	CR ≥ 100 @Any Other Angle	35	40	--	Degrees	1,2,3
No Gray Inversion Angle	θ	Any Angle	90	--	--	Degrees	1,2,3
White Uniformity		Optimal	65	80	--	%	1,2,5
Flicker	F	No Visual Flicker	--	--	-30	dB	1,2,3
Cross Talk	D _{SHA}	No Visible Cross-talk	--	--	2	%	1,2,3
Gamma		--	--	2.2	--	--	1,2,3

Note (1): Measuring Conditions

The optical characteristics are determined after the unit has been 'ON' and stable at the maximum brightness, in a dark environment at an ambient temperature at $25^{\circ}\text{C} \pm 2^{\circ}\text{C}$. The electrical conditions include $V_{\text{CCS}} = 3.3 \text{ V}$, $f_v = 60 \text{ Hz}$, $f_{\text{CLK}} = 100 \text{ MHz}$, $I_{\text{LED}} = 20.0 \text{ mA}$. Recommended measuring equipments for luminance and color is Photo Research PR650 Colorimeter or similar. The measuring distance should be about 30-50 cm from the LCD surface at normal unless otherwise specified. The (virtual) measuring spot should be 5mm in diameter. The CIE 1931 and 1967 Standards shall be used. Measurements should be done on the 13 grid points as shown in the following figures. Viewing angle measurements should be done by an Eldim EZ Color system or similar.

Note (2): Optical Measurement Set-up

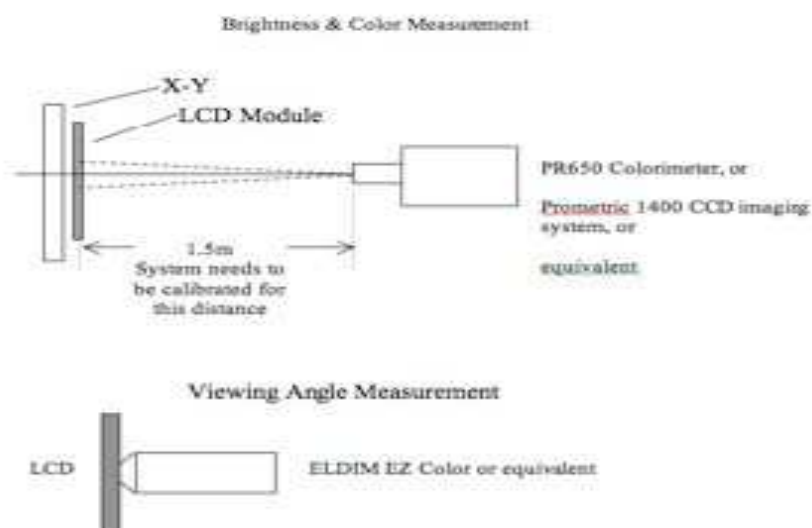

Center Point Luminance

Lct = Luminance at point # 5 point of the display

Average Luminance

Lave = SUM (L1:L13) / 13 where L1 to L13 are the luminance values measured at point #1 to #13.

White Uniformity:

Luminance is measured at the following thirteen points (1~13) :

$$\delta_{W(13)} = \frac{\text{Maximum brightness of thirteen points}}{\text{Minimum brightness of thirteen points}}$$

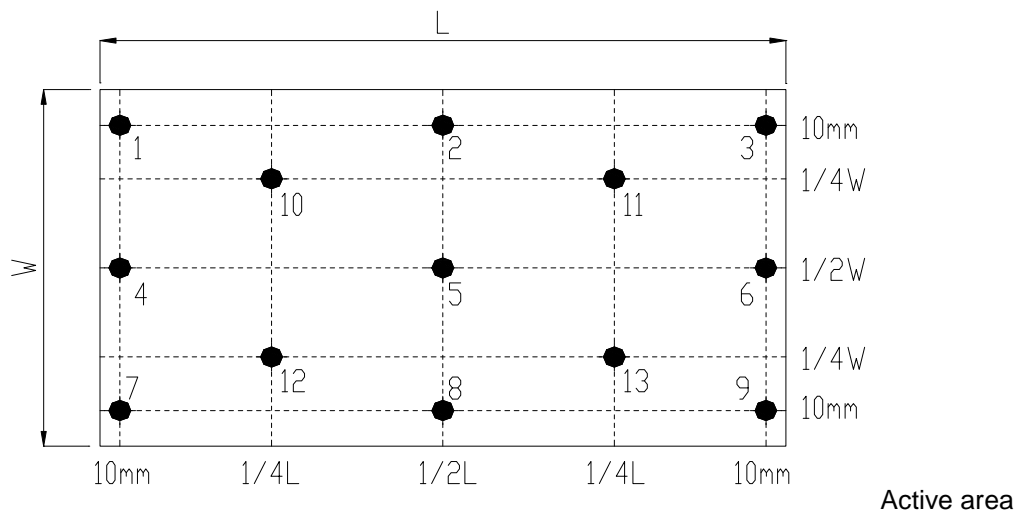

Contrast Ratio

CR = Luminance at White / Luminance at Black.

RGB Color Chromaticity

The entire display active area shall be scanned with the color coordinate measurement with screen set to full brightness and solid R, G, B color respectively. The measured color coordinate of any panel shall be within the box with 4 corners

Viewing Angle

The viewing angle is defined as the viewing angle range under the condition at CR > 100:1 .

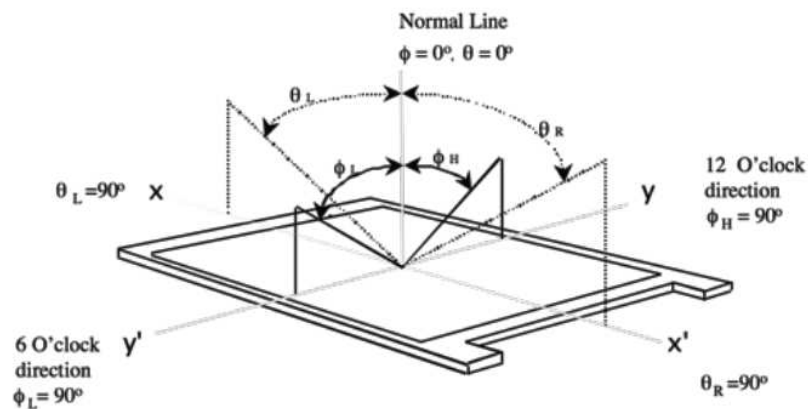

Response Time

The On/Off response time, $\tau_R \pm \tau_F$, is defined in the following figure and shall be measured by switching the input signal for "black" and "white".

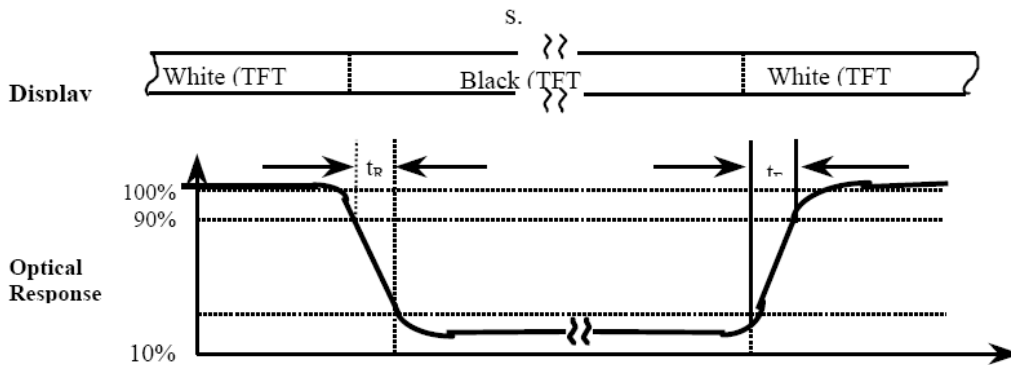

Gray to Gray Response Time is measured in a similar method. But instead of switching display between black and white, panel is switched between two gray scales. The maximum gray-to-gray response time is based on 9 levels of gray scales. The 9 levels are: gray level 255, 223, 191, 159, 127, 95, 63, 32 and 0.

Gray Scale Linearity or Gamma Value

The display luminance, L_G , is measured at the different gray scales, G_{min}, \dots, G_{max} . The exponential fitting is used to determine the gamma (γ) value, which should be an intrinsic or uncorrected characteristic.

$$L_G \sim G^\gamma.$$

Flicker

No visual flicker will be allowed. The flicker level should be measured on GS223, GS191, GS159, GS127, GS95, GS63, GS31. The output signal of a photometer is sent to an FFT analyzer. The flicker is essentially a ratio of the powers in the frequency spectrum at 30 Hz (P_x) and 0 Hz (P_0), i.e., $F = 10 \text{ Log} (P_x / P_0)$.

Cross-Talk

No visual cross-talk will be allowed. Two luminance values are measured at center spot with 50 x 50 pixels. The cross-talk, D_{SHA} , is defined as, $D_{SHA} = (L_B - L_A) / L_B \cdot 100\%$, Where, L_A = Luminance in Pattern A L_B = Luminance in Pattern B.

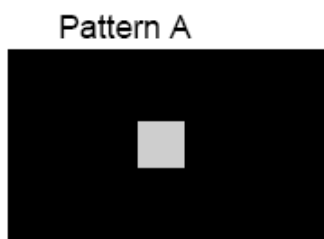

Gray Scale = 127/255
Black in surrounding



Gray Scale = 127/255
full screen

Note (3): Measured at center point. Equivalent performance over the entire panel required.

Note (4): Both center point luminance and average luminance of 160 13 points.

Note (5): All 160 13 points measurement required.

6. RELIABILITY TEST ITEM

Test Item	Test Condition	Note
High Temperature Storage Test	65°C, 500 hours	(1) (2)
Low Temperature Storage Test	-25°C, 500 hours	
Thermal Shock Storage Test	-25°C, 25Min \longleftrightarrow 65°C, 25Min; Cycle display from -25°C to 65°C with 5-minute transfer time, total 100cycles,	
High Temperature Operation Test	50°C, 500 hours	
Low Temperature Operation Test	0°C, 500 hours	
High Temperature & High Humidity Operation Test	50°C, RH 80%, 240hours	
ESD Test	150pF, 330 Ω , 1sec/cycle,25 times/point Condition 1 : Contact Discharge, \pm 4KV Condition 2 : Air Discharge, \pm 8KV	
Shock (Non-Operating)	Condition 1: Shock Level: 200G/ 2ms; Waveform: half sine wave, One shock for each direction \pm X, \pm Y, \pm Z; Condition 2: Shock Level: 260G/ 2ms; Waveform: half sine wave, One shock for each direction \pm X, \pm Y, \pm Z; Condition 3: Shock Level: 60G/ 11ms; Waveform: half sine wave, One shock for each direction \pm X, \pm Y, \pm Z;	(1)(3)
Vibration (Non-Operating)	Vibration Level: 3.0G.Bandwidth: 5-150HZ Waveform: sine wave, 0.37Oct/min; 30min for each direction X, Y, Z (1.5Hrs in total)	(1)(3)

Note (1) criteria: Normal display image with no obvious non-uniformity and no line defect.

Note (2) Evaluation should be tested after storage at room temperature for more than two hour

Note (3) At testing Vibration and Shock, the fixture in holding the module has to be hard and rigid enough so that the module would not be twisted or bent by the fixture.

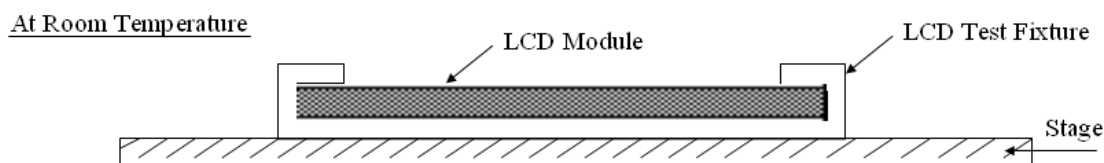

7. PACKING

7.1 MODULE LABEL

The barcode nameplate is pasted on each module as illustration, and its definitions are as following explanation.



(a) Product Number : AB097000XXXX

(b) Serial ID I : Z₁Z₂Z₃Z₄Z₅Z₆-Z₇-Z₈Z₉Z₁₀Z₁₁Z₁₂

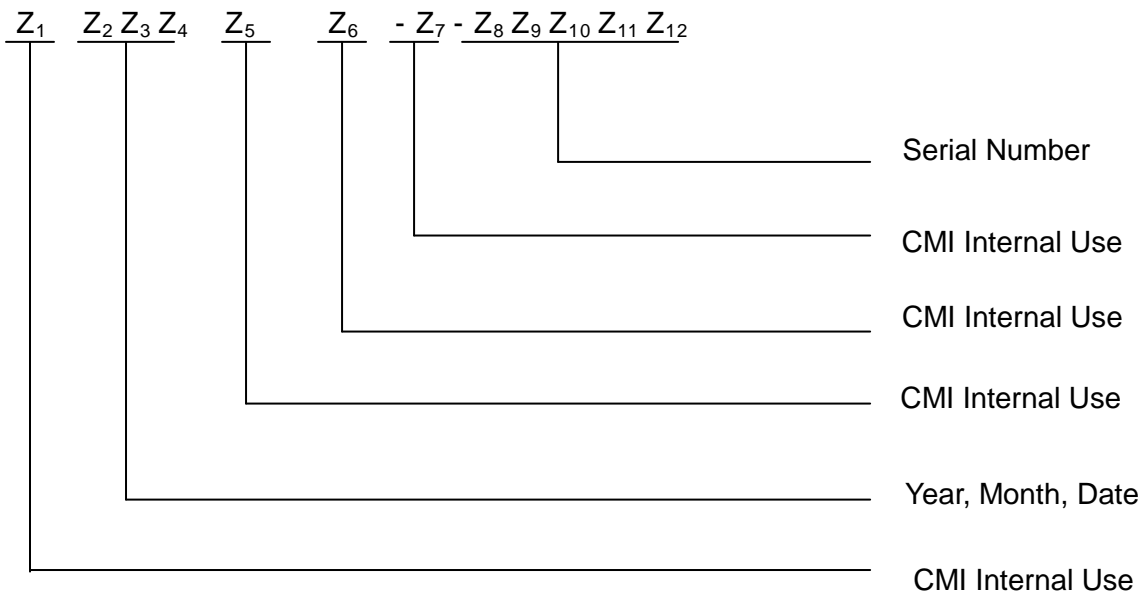

Serial ID includes the information as below:

(a) Manufactured Date:

Year: 0~9, for 2010~2019;

Month: 1~9 & A~C for Jan.~Dec.;

Date: 1~9 & A~Z (Exclude I,O,Q,U) for 1st~31st.

(b) Serial Number: Module packing sequence number

7.2 CARTON

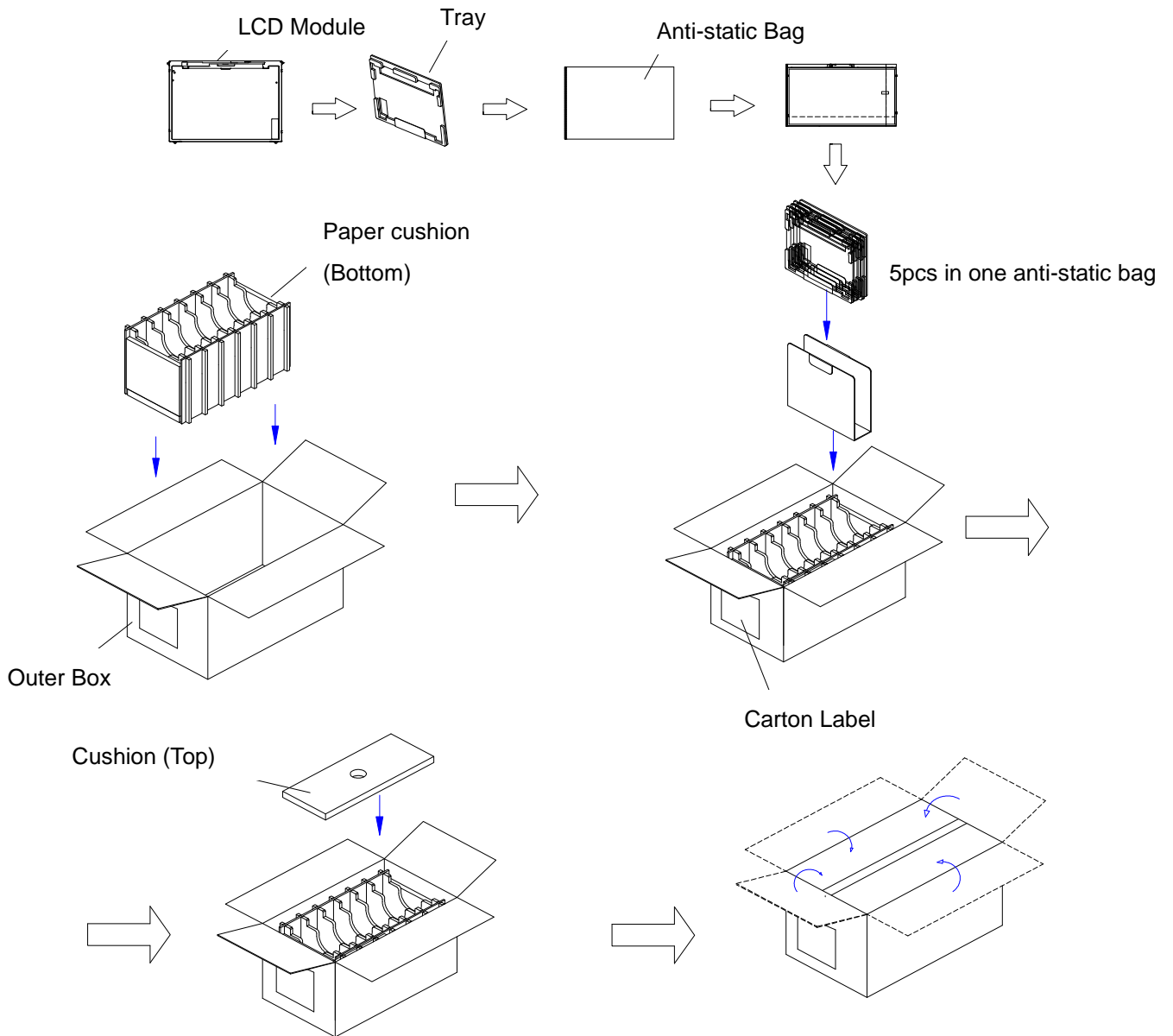

Figure. 7-2 Packing

7.3 PALLET

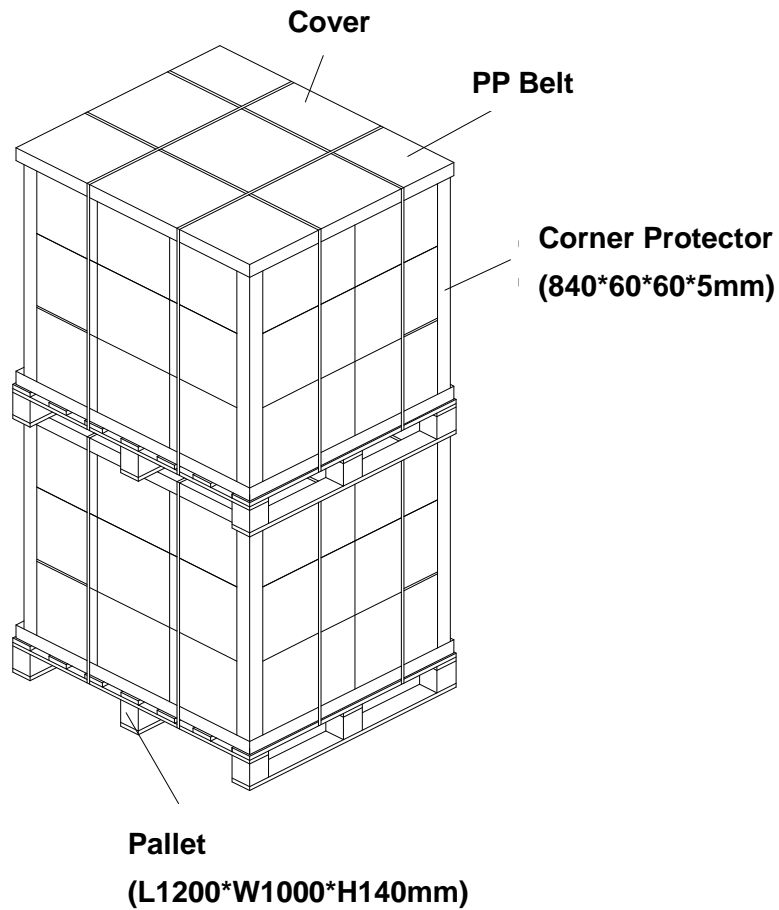

Figure. 7-3 Packing

8. PRECAUTIONS

8.1 HANDLING PRECAUTIONS

- (1) The module should be assembled into the system firmly by using every mounting hole. Be careful not to twist or bend the module.
- (2) While assembling or installing modules, it can only be in the clean area. The dust and oil may cause electrical short or damage the polarizer.
- (3) Use fingerstalls or soft gloves in order to keep display clean during the incoming inspection and assembly process.
- (4) Do not press or scratch the surface harder than a HB pencil lead on the panel because the polarizer is very soft and easily scratched.
- (5) If the surface of the polarizer is dirty, please clean it by some absorbent cotton or soft cloth. Do not use Ketone type materials (ex. Acetone), Ethyl alcohol, Toluene, Ethyl acid or Methyl chloride. It might permanently damage the polarizer due to chemical reaction.
- (6) Wipe off water droplets or oil immediately. Staining and discoloration may occur if they left on panel for a long time.
- (7) If the liquid crystal material leaks from the panel, it should be kept away from the eyes or mouth. In case of contacting with hands, legs or clothes, it must be washed away thoroughly with soap.
- (8) Protect the module from static electricity, it may cause damage to the C-MOS Gate Array IC.
- (9) Do not disassemble the module.
- (10) Do not pull or fold the LED wire.
- (11) Pins of I/F connector should not be touched directly with bare hands.

8.2 STORAGE PRECAUTIONS

- (1) High temperature or humidity may reduce the performance of module. Please store LCD module within the specified storage conditions.
- (2) It is dangerous that moisture come into or contacted the LCD module, because the moisture may damage LCD module when it is operating.
- (3) It may reduce the display quality if the ambient temperature is lower than 10 °C. For example, the response time will become slowly.

8.3 OPERATION PRECAUTIONS

- (1) Do not pull the I/F connector in or out while the module is operating.
- (2) Always follow the correct power on/off sequence when LCD module is connecting and operating. This can prevent the CMOS LSI chips from damage during latch-up.
- (3) Do not disassemble the module or insert anything into the Backlight unit.

Appendix. OUTLINE DRAWING

