 HannStar Display Corp.			
Document Title	HSD070PFW3-A Preliminary Specification	Page No.	1/25
Document No.	DC110-000851	Revision	2.0

TO :

Date : May 03, 2011

HannStar Product Specification **(Preliminary)**

Model: HSD070PFW3
-A00

Note:

1. The information contained herein is preliminary and may be changed without prior notices.
2. Please contact HannStar Display Corp. before designing your product based on this module specification.
3. The information contained herein is presented merely to indicate the characteristics and performance of our products. No responsibility is assumed by HannStar for any intellectual property claims or other problems that may result from application based on the module described herein.



HannStar Display Corp.

Document Title	HSD070PFW3-A Preliminary Specification	Page No.	2/25
Document No.	DC110-000851	Revision	2.0

Record of Revisions

Rev.	Date	Sub-Model	Description of change
1.0	Mar 10 2011	-A00	Product specification was first released
1.1	Mar 16 2011	-A00	P6 White Luminance: 5 points→Center P18 High/Low Temperature Operation 500hrs→240hrs
2.0	May 03 2011	-A00	P4 Modify surface treatment: AG→Hard coating Modify weight:130g→104g P11 Add 6bit relationship between display color and input P14 Modify pin define P15 Modify Vcom value and current of power supply & note P16 Add 6bit LVDS input P20 Modify outline drawing



Document Title	HSD070PFW3-A Preliminary Specification	Page No.	3/25
Document No.	DC110-000851	Revision	2.0

Contents

1.0	General description	p.4
2.0	Absolute maximum ratings.....	p.5
3.0	Optical characteristics.....	p.6
4.0	Block diagram	p.10
5.0	Interface pin connection	p.12
6.0	Electrical characteristics	p.14
7.0	Reliability test items	p.21
8.0	Outline dimension	p.22
9.0	Lot mark	p.24
10.0	Package specification	p.25
11.0	General precaution	p.26

Document Title	HSD070PFW3-A Preliminary Specification	Page No.	4/25
Document No.	DC110-000851	Revision	2.0

1.0 GENERAL DESCRIPTION

1.1 Introduction

HannStar Display model HSD070PFW3-A00 is a color active matrix thin film transistor (TFT) liquid crystal display (LCD) that uses amorphous silicon TFT as a switching device. This model is composed of a TFT LCD panel, a driving circuit and a back light system. This TFT LCD has a 7.0 (17:10) inch diagonally measured active display area with WSVGA (1024 horizontal by 600 vertical pixel) resolution.

1.2 Features

- 7 inch (17:10 diagonal) configuration
- 16.7M color by 6 bit+HFRC R.G.B signal input
- RoHS/ Halogen Free Compliance

1.3 Applications

- Mobile NB
- Digital Photo frame
- Display terminal for AV application

1.4 TFT LCD General information

Item	Specification	Unit
Outline Dimension	165.75 x 105.39 (typ)	mm
Display area	153.6(H) x 90(V)	mm
Number of Pixel	1024 RGB (H) x 600(V)	pixels
Pixel pitch	0.15(H) x 0.15(V)	mm
Pixel arrangement	RGB Vertical stripe	
Display mode	Normally white	
NTSC	50 (typ.)	%
Surface treatment	Hard coating with EWV Flim	
Weight	(104g) (Typ.)	g
Back-light	White LED	
Power Consumption	BL System 1.2 @ Black pattern w/o LED driver	W

1.5 Mechanical Information

Item	Min.	Typ.	Max.	Unit	Remark	
Module Size	Horizontal (H)	165.45	165.75	166.05	mm	
	Vertical (V)	105.09	105.39	105.69	mm	
	Depth (D)	—	3.4	3.7	mm	
Weight	—	(104)	—	g		

Document Title	HSD070PFW3-A Preliminary Specification	Page No.	5/25
Document No.	DC110-000851	Revision	2.0

2.0 ABSOLUTE MAXIMUM RATINGS

2.1 Electrical Absolute Rating

2.1.1 TFT LCD Module

Item	Symbol	Min.	Max.	Unit	Note
Power supply voltage	V_{DD}	-0.3	5.0	V	
	V_{GH}	-0.3	20.0	V	
	V_{GL}	-20.0	0.3	V	
	AV_{DD}	6.5	13.5	V	
	V_I	-0.3	$V_{DD} + 0.3$	V	
Logic Signal Input Level	V_{DD}	-0.3	5.0	V	

2.1.2

Item	Symbol	Typ.	Max.	Unit	Note
LED current	I_L	120	—	mA	(1) (2)(3)
LED voltage	V_L	10.5	—	V	(1) (2)(3)

Note

- (1) Permanent damage may occur to the LCD module if beyond this specification. Functional operation should be restricted to the conditions described under normal operating conditions.
- (2) $T_a = 25 \pm 2^\circ\text{C}$
- (3) Test Condition: LED current 120 mA. The LED lifetime could be decreased if operating I_L is larger than 120mA.

2.1.3 Environment Absolute Rating

Item	Symbol	Min.	Max.	Unit	Note
Operating Temperature	T_{opa}	-20	60	$^\circ\text{C}$	
Storage Temperature	T_{stg}	-30	70	$^\circ\text{C}$	

Document Title	HSD070PFW3-A Preliminary Specification	Page No.	6/25
Document No.	DC110-000851	Revision	2.0

3.0 OPTICAL CHARACTERISTICS

3.1 Optical specification

Item		Symbol	Condition	Min.	Typ.	Max.	Unit	Note
Contrast		CR	$\theta=0$ Normal viewing angle	—	800	—		(1)(2)(4)
Response time		Tr		—	4	8	msec	(1)(3)
		Tf		—	12	24		
White luminance (Center)		Y_L		—	250	—	cd/m ²	(1)(4)
Color chromaticity (CIE1931)	Red	R_x			TBD			
		R_y			TBD			
	Green	G_x			TBD			
		G_y			TBD			
	Blue	B_x			TBD			
		B_y			TBD			
	White	W_x	0.260	0.310	0.360			
		W_y	0.280	0.330	0.380			
Viewing angle	Hor.	θ_L	CR>10	70	80	—	(1)(4)	
		θ_R		70	80	—		
	Ver.	θ_U		70	80	—		
		θ_D		60	70	—		
Brightness uniformity		B_{UNI}	$\theta=0$ (9point)	70	75	—		(5)
View Direction		6 O' clock						(6)

3.2 Measuring Condition

- Measuring surrounding : dark room
- LED current I_L : 120mA
- Ambient temperature : 25±2°C
- 15min. warm-up time.

Document Title	HSD070PFW3-A Preliminary Specification	Page No.	7/25
Document No.	DC110-000851	Revision	2.0

3.3 Measuring Equipment

- FPM520 of Westar Display technologies, INC., which utilized SR-3 for Chromaticity and BM-5A for other optical characteristics.
- Measuring spot size : 20 ~ 21 mm

Note (1) Definition of Viewing Angle:

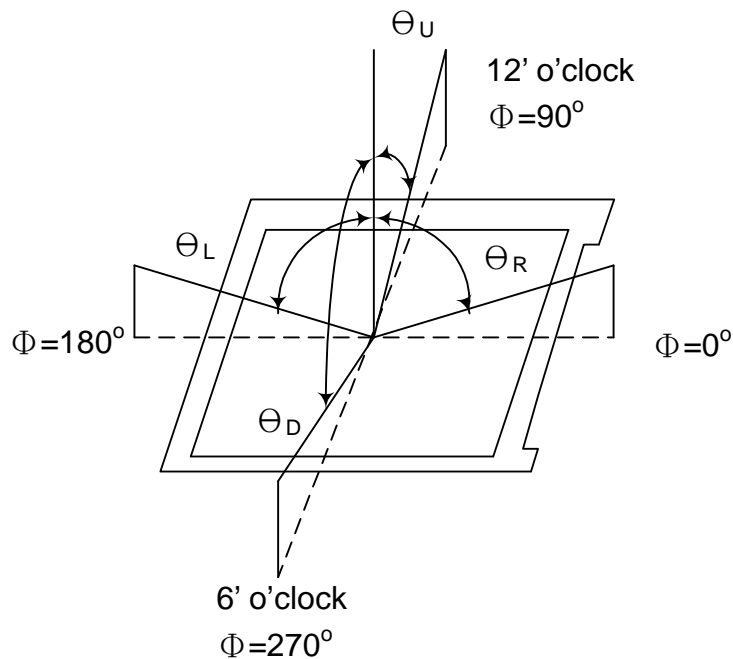

Note (2) Definition of Contrast Ratio (CR) :
measured at the center point of panel

$$CR = \frac{\text{Luminance with all pixels white}}{\text{Luminance with all pixels black}}$$

Document Title	HSD070PFW3-A Preliminary Specification	Page No.	8/25
Document No.	DC110-000851	Revision	2.0

Note (3) Definition of Response Time : Sum of T_R and T_F

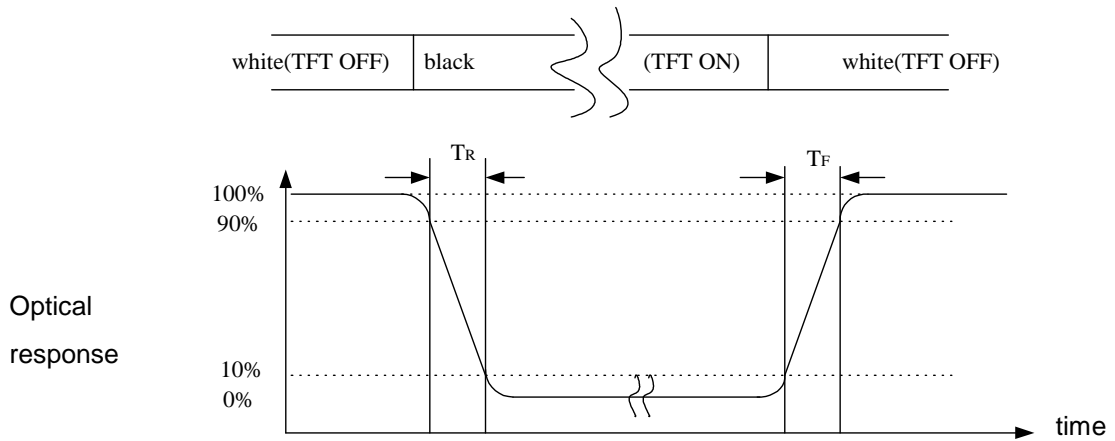

Note (4) Definition of optical measurement setup

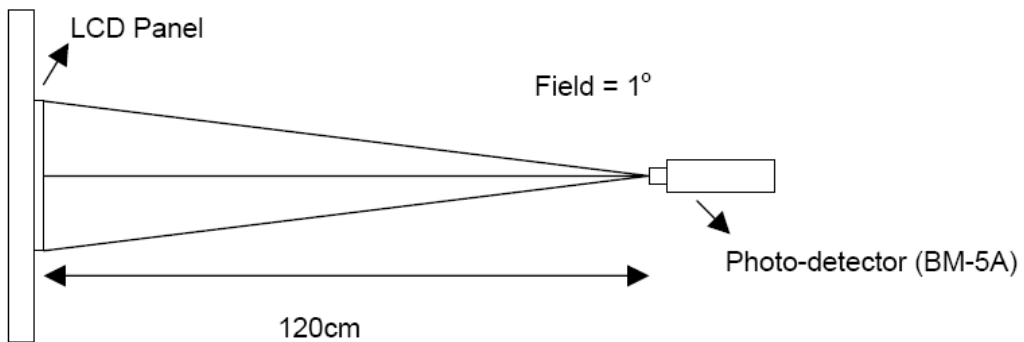

Document Title	HSD070PFW3-A Preliminary Specification	Page No.	9/25
Document No.	DC110-000851	Revision	2.0

Note (5) Definition of Average Luminance Uniformity of White (Center)
Definition of brightness uniformity

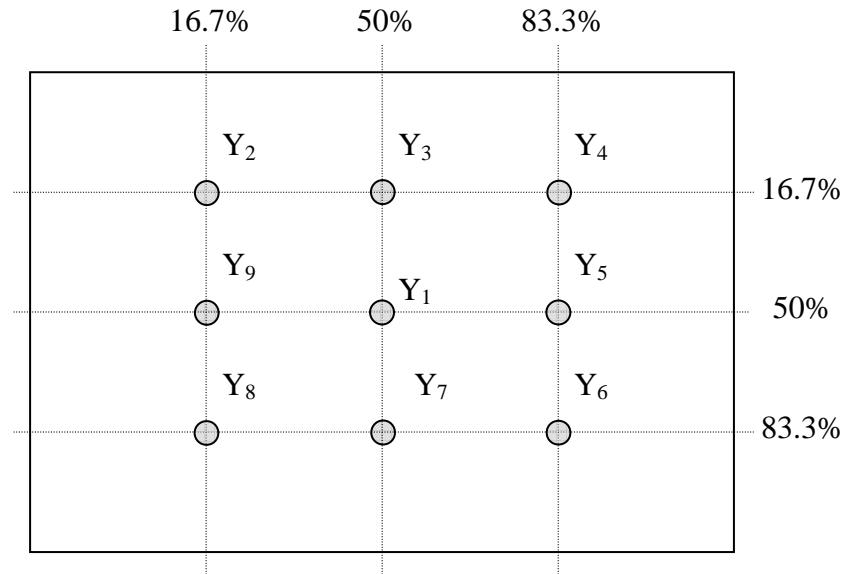

$$\text{Luminance uniformity} = \frac{(\text{Min Luminance of 9 points})}{(\text{Max Luminance of 9 points})} \times 100\%$$

Note (6) Rubbing Direction (The different Rubbing Direction will cause the different optimal view direction.)

Document Title	HSD070PFW3-A Preliminary Specification	Page No.	10/25
Document No.	DC110-000851	Revision	2.0

4.0 BLOCK DIAGRAM

4.1 TFT LCD Module

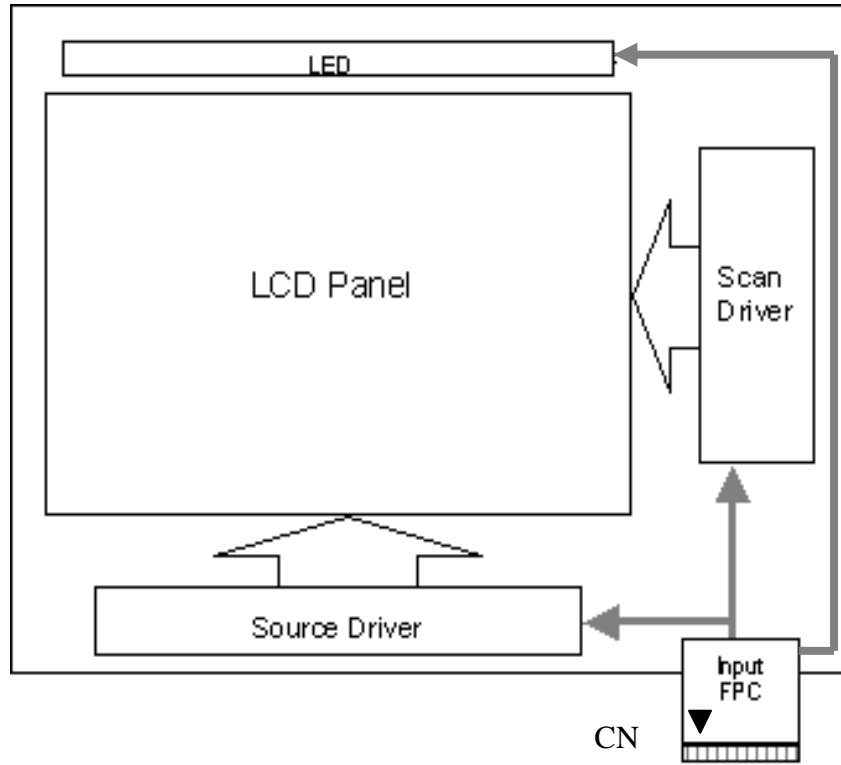

4.2 Pixel Format

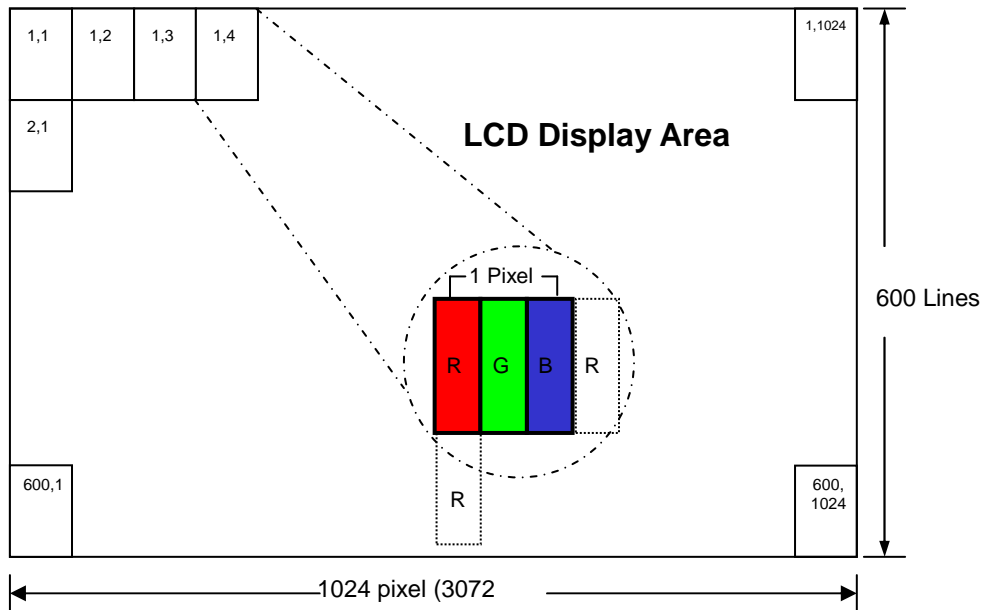

Document Title	HSD070PFW3-A Preliminary Specification	Page No.	11/25
Document No.	DC110-000851	Revision	2.0

Relationship Between Displayed Color and Input

4.3.1 6bit

	Display	MSB LSB						M		S		B		Gray scale level					
		R5	R4	R3	R2	R1	R0	G5	G4	G3	G2	G1	G0		B5	B4	B3	B2	B1
Basic color	Black	L	L	L	L	L	L	L	L	L	L	L	L	L	L	L	L	L	-
	Blue	L	L	L	L	L	L	L	L	L	L	L	H	H	H	H	H	H	-
	Green	L	L	L	L	L	L	H	H	H	H	H	L	L	L	L	L	L	-
	Light Blue	L	L	L	L	L	L	H	H	H	H	H	H	H	H	H	H	H	-
	Red	H	H	H	H	H	H	L	L	L	L	L	L	L	L	L	L	L	-
	Purple	H	H	H	H	H	H	L	L	L	L	L	H	H	H	H	H	H	-
	Yellow	H	H	H	H	H	H	H	H	H	H	H	L	L	L	L	L	L	-
	White	H	H	H	H	H	H	H	H	H	H	H	H	H	H	H	H	H	-
Gray scale of Red	Black	L	L	L	L	L	L	L	L	L	L	L	L	L	L	L	L	L	L0
	Dark ↑ ↓ Light	L	L	L	L	L	H	L	L	L	L	L	L	L	L	L	L	L	L1
		L	L	L	L	H	L	L	L	L	L	L	L	L	L	L	L	L	L2
		:	:	:	:	:	:	:	:	:	:	:	:	:	:	:	:	:	L3...L60
	H	H	H	H	L	H	L	L	L	L	L	L	L	L	L	L	L	L61	
	H	H	H	H	H	L	L	L	L	L	L	L	L	L	L	L	L	L62	
Red	H	H	H	H	H	H	L	L	L	L	L	L	L	L	L	L	L	Red L63	
Gray scale of Green	Black	L	L	L	L	L	L	L	L	L	L	L	L	L	L	L	L	L	L0
	Dark ↑ ↓ Light	L	L	L	L	L	L	L	L	L	L	L	H	L	L	L	L	L	L1
		L	L	L	L	L	L	L	L	L	L	H	L	L	L	L	L	L	L2
		:	:	:	:	:	:	:	:	:	:	:	:	:	:	:	:	:	L3...L60
	L	L	L	L	L	L	H	H	H	H	L	H	L	L	L	L	L	L61	
	L	L	L	L	L	L	H	H	H	H	H	L	L	L	L	L	L	L62	
Green	L	L	L	L	L	L	H	H	H	H	H	L	L	L	L	L	L	Green L63	
Gray scale of Blue	Black	L	L	L	L	L	L	L	L	L	L	L	L	L	L	L	L	L	L0
	Dark ↑ ↓ Light	L	L	L	L	L	L	L	L	L	L	L	L	L	L	L	L	H	L1
		L	L	L	L	L	L	L	L	L	L	L	L	L	L	L	H	L	L2
		:	:	:	:	:	:	:	:	:	:	:	:	:	:	:	:	:	L3...L60
	L	L	L	L	L	L	L	L	L	L	L	H	H	H	H	L	H	L61	
	L	L	L	L	L	L	L	L	L	L	L	H	H	H	H	H	L	L62	
Blue	L	L	L	L	L	L	L	L	L	L	L	H	H	H	H	H	H	Blue L63	
Gray scale of White & Black	Black	L	L	L	L	L	L	L	L	L	L	L	L	L	L	L	L	L	L0
	Dark ↑ ↓ Light	L	L	L	L	L	H	L	L	L	L	L	H	L	L	L	L	H	L1
		L	L	L	L	H	L	L	L	L	L	H	L	L	L	L	H	L	L2
		:	:	:	:	:	:	:	:	:	:	:	:	:	:	:	:	:	L3...L60
	H	H	H	H	L	H	H	H	H	H	L	H	H	H	H	L	H	L61	
	H	H	H	H	H	L	H	H	H	H	H	L	H	H	H	H	L	L62	
White	H	H	H	H	H	H	H	H	H	H	H	H	H	H	H	H	H	White L63	

Document Title	HSD070PFW3-A Preliminary Specification	Page No.	12/25
Document No.	DC110-000851	Revision	2.0

4.3.2 8bit

Display	MSB								LSB								MSB								LSB								Gray scale Level
	R7	R6	R5	R4	R3	R2	R1	R0	G7	G6	G5	G4	G3	G2	G1	G0	B7	B6	B5	B4	B3	B2	B1	B0									
Basic color	Black	L	L	L	L	L	L	L	L	L	L	L	L	L	L	L	L	L	L	L	L	L	L	L	L	-							
	Blue	L	L	L	L	L	L	L	L	L	L	L	L	L	L	L	L	H	H	H	H	H	H	H	H	-							
	Green	L	L	L	L	L	L	L	L	H	H	H	H	H	H	H	H	L	L	L	L	L	L	L	L	-							
	Light Blue	L	L	L	L	L	L	L	L	H	H	H	H	H	H	H	H	H	H	H	H	H	H	H	H	-							
	Red	H	H	H	H	H	H	H	H	L	L	L	L	L	L	L	L	L	L	L	L	L	L	L	L	-							
	Purple	H	H	H	H	H	H	H	H	L	L	L	L	L	L	L	L	H	H	H	H	H	H	H	H	-							
	Yellow	H	H	H	H	H	H	H	H	H	H	H	H	H	H	H	H	L	L	L	L	L	L	L	L	-							
	White	H	H	H	H	H	H	H	H	H	H	H	H	H	H	H	H	H	H	H	H	H	H	H	H	-							
Gray scale of Red	Black	L	L	L	L	L	L	L	L	L	L	L	L	L	L	L	L	L	L	L	L	L	L	L	L	L0							
	Dark ↑ ↓ Light	L	L	L	L	L	L	L	L	H	L	L	L	L	L	L	L	L	L	L	L	L	L	L	L	L	L1						
		L	L	L	L	L	L	L	L	H	L	L	L	L	L	L	L	L	L	L	L	L	L	L	L	L	L2						
		:	:	:	L3...L251																												
		H	H	H	H	H	H	L	L	L	L	L	L	L	L	L	L	L	L	L	L	L	L	L	L	L	L252						
	H	H	H	H	H	H	L	H	L	L	L	L	L	L	L	L	L	L	L	L	L	L	L	L	L	L253							
	H	H	H	H	H	H	H	L	L	L	L	L	L	L	L	L	L	L	L	L	L	L	L	L	L	L254							
	Red	H	H	H	H	H	H	H	L	L	L	L	L	L	L	L	L	L	L	L	L	L	L	L	Red L255								
Gray scale of Green	Black	L	L	L	L	L	L	L	L	L	L	L	L	L	L	L	L	L	L	L	L	L	L	L	L	L0							
	Dark ↑ ↓ Light	L	L	L	L	L	L	L	L	L	L	L	L	L	L	L	H	L	L	L	L	L	L	L	L	L	L1						
		L	L	L	L	L	L	L	L	L	L	L	L	L	L	L	H	L	L	L	L	L	L	L	L	L	L2						
		:	:	:	L3...L251																												
		L	L	L	L	L	L	L	L	H	H	H	H	H	L	L	L	L	L	L	L	L	L	L	L	L252							
	L	L	L	L	L	L	L	L	H	H	H	H	H	L	H	L	L	L	L	L	L	L	L	L	L253								
	L	L	L	L	L	L	L	L	H	H	H	H	H	H	L	L	L	L	L	L	L	L	L	L	L254								
	Green	L	L	L	L	L	L	L	H	H	H	H	H	H	H	H	L	L	L	L	L	L	L	L	Green L255								
Gray scale of Blue	Black	L	L	L	L	L	L	L	L	L	L	L	L	L	L	L	L	L	L	L	L	L	L	L	L	L0							
	Dark ↑ ↓ Light	L	L	L	L	L	L	L	L	L	L	L	L	L	L	L	L	L	L	L	L	L	L	L	H	L	L1						
		L	L	L	L	L	L	L	L	L	L	L	L	L	L	L	L	L	L	L	L	L	L	H	L	L2							
		:	:	:	L3...L251																												
		L	L	L	L	L	L	L	L	L	L	L	L	L	L	L	L	H	H	H	H	H	L	L	L	L252							
	L	L	L	L	L	L	L	L	L	L	L	L	L	L	L	L	H	H	H	H	H	L	H	L	L253								
	L	L	L	L	L	L	L	L	L	L	L	L	L	L	L	L	H	H	H	H	H	H	L	L	L254								
	Blue	L	L	L	L	L	L	L	L	L	L	L	L	L	L	L	H	H	H	H	H	H	H	H	Blue L255								
Gray scale of White & Black	Black	L	L	L	L	L	L	L	L	L	L	L	L	L	L	L	L	L	L	L	L	L	L	L	L	L0							
	Dark ↑ ↓ Light	L	L	L	L	L	L	L	H	L	L	L	L	L	L	H	L	L	L	L	L	L	L	H	L	L1							
		L	L	L	L	L	L	L	H	L	L	L	L	L	L	H	L	L	L	L	L	L	L	H	L	L2							
		:	:	:	L3...L251																												
		H	H	H	H	H	L	L	H	H	H	H	L	L	H	H	H	H	L	L	L	L	L	L	L	L	L252						
	H	H	H	H	H	L	H	H	H	H	H	L	H	H	H	H	H	L	H	L	L	L	L	L	L	L253							
	H	H	H	H	H	H	L	H	H	H	H	H	L	H	H	H	H	H	L	L	L	L	L	L	L	L254							
	White	H	H	H	H	H	H	H	H	H	H	H	H	H	H	H	H	H	H	H	H	H	H	H	White L255								

Document Title	HSD070PFW3-A Preliminary Specification	Page No.	13/25
Document No.	DC110-000851	Revision	2.0

5.0 INTERFACE PIN CONNECTION

FPC connector is used for electronics interface. The recommended model is FH12A-40S-0.5SH manufactured by Hirose.

Pin No.	Symbol	I/O	Function	Note
1	VCOM	P	Common Voltage	
2	VDD	P	Power Voltage for digital circuit	
3	VDD	P	Power Voltage for digital circuit	
4	NC	---	No connection	
5	Reset	I	Global reset pin	
6	STBYB	I	Standby mode, Normally pulled high STBYB = "1", normal operation STBYB = "0", timing controller, source driver will turn off, all output are High-Z	
7	GND	P	Ground	
8	RXIN0-	I	- LVDS differential data input	
9	RXIN0+	I	+ LVDS differential data input	
10	GND	P	Ground	
11	RXIN1-	I	- LVDS differential data input	
12	RXIN1+	I	+ LVDS differential data input	
13	GND	P	Ground	
14	RXIN2-	I	- LVDS differential data input	
15	RXIN2+	I	+ LVDS differential data input	
16	GND	P	Ground	
17	RXCLKIN-	I	- LVDS differential clock input	
18	RXCLKIN+	I	+ LVDS differential clock input	
19	GND	P	Ground	
20	RXIN3-	I	- LVDS differential data input	
21	RXIN3+	I	+ LVDS differential data input	
22	GND	P	Ground	
23	NC	---	No connection	
24	NC	---	No connection	
25	GND	P	Ground	
26	NC	---	No connection	
27	NC	---	No connection	
28	SELB	I	6bit/8bit mode selection	Note1
29	AVDD	P	Power for Analog Circuit	
30	GND	P	Ground	



Document Title	HSD070PFW3-A Preliminary Specification	Page No.	14/25
Document No.	DC110-000851	Revision	2.0

Pin No.	Symbol	I/O	Function	Note
31	LED-	P	LED Cathode	
32	LED-	P	LED Cathode	
33	L/R	I	Horizontal inversion	Note2
34	U/D	I	Vertical inversion	Note2
35	VGL	P	Gate off Voltage	
36	NC	---	No connection	
37	NC	---	No connection	
38	VGH	P	Gate ON Voltage	
39	LED+	P	LED Anode	
40	LED+	P	LED Anode	

I: input O: Output P: Power

Note1 : If LVDS input data is 6 bits ,SELB must be set to High;

If LVDS input data is 8 bits, SELB must be set to Low.

Note2 : When L/R="0", set right to left scan direction.

When L/R="1", set left to right scan direction.

When U/D="0", set top to bottom scan direction.

When U/D="1", set bottom to top scan direction.

Document Title	HSD070PFW3-A Preliminary Specification	Page No.	15/25
Document No.	DC110-000851	Revision	2.0

6.0 ELECTRICAL CHARACTERISTICS

6.1 TFT LCD Module

Item	Symbol	Min.	Typ.	Max.	Unit	Note
Supply Voltage	V_{DD}	3.0	3.3	3.6	V	
	V_{GH}	19.7	20	20.3	V	
	V_{GL}	-6.5	-6.8	-7.1	V	
	AV_{DD}	10.8	11	11.2	V	
VCOM	V_{COMin}	3.46	3.66	3.86	V	
Input signal voltage	V_{iH}	$0.7 V_{DD}$	-	V_{DD}	V	Note (1)
	V_{iL}	0	-	$0.3 V_{DD}$	V	
Current of power supply	I_{DD}	-	25	-	mA	$V_{DD}=3.3V$
	I_{ADD}	-	35	-	mA	$AV_{DD}=11V$
	I_{GH}	-	0.45	-	mA	$V_{GH}=20V$
	I_{GL}	-	0.85	-	mA	$V_{GL}=-6.8V$

6.2 Switching Characteristics for LVDS Receiver

Item	Symbol	Min.	Typ.	Max.	Unit	Conditions
Differential Input High Threshold	V_{th}	—	—	100	mV	$V_{CM}=1.2V$
Differential Input Low Threshold	V_{tl}	-100	—	—	mV	
Input Current	I_{IN}	-10	—	+10	uA	
Differential input Voltage	$ V_{ID} $	0.1	—	0.6	V	
Common Mode Voltage Offset	V_{CM}	0.7	1.2	1.6	V	

Document Title	HSD070PFW3-A Preliminary Specification	Page No.	16/25
Document No.	DC110-000851	Revision	2.0

6.3 Bit LVDS input

6.3.1 6bit LVDS input

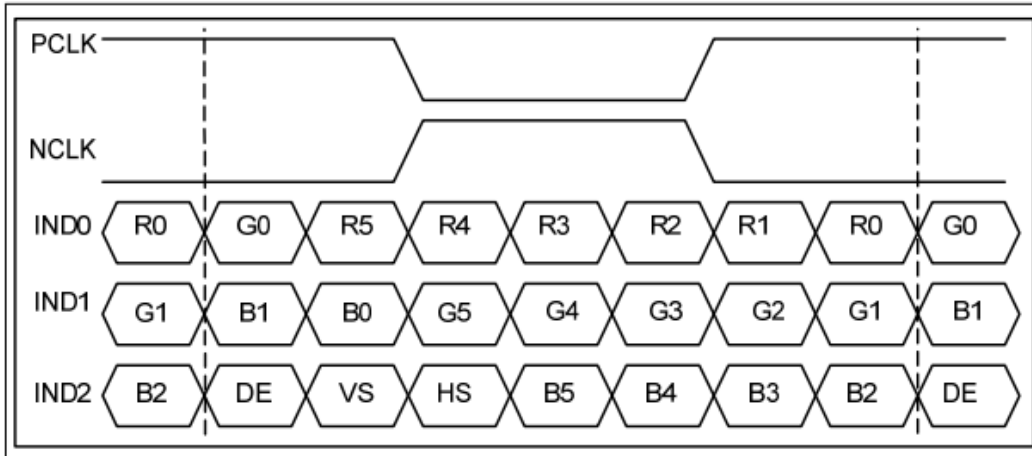

6.3.2 8Bit LVDS input

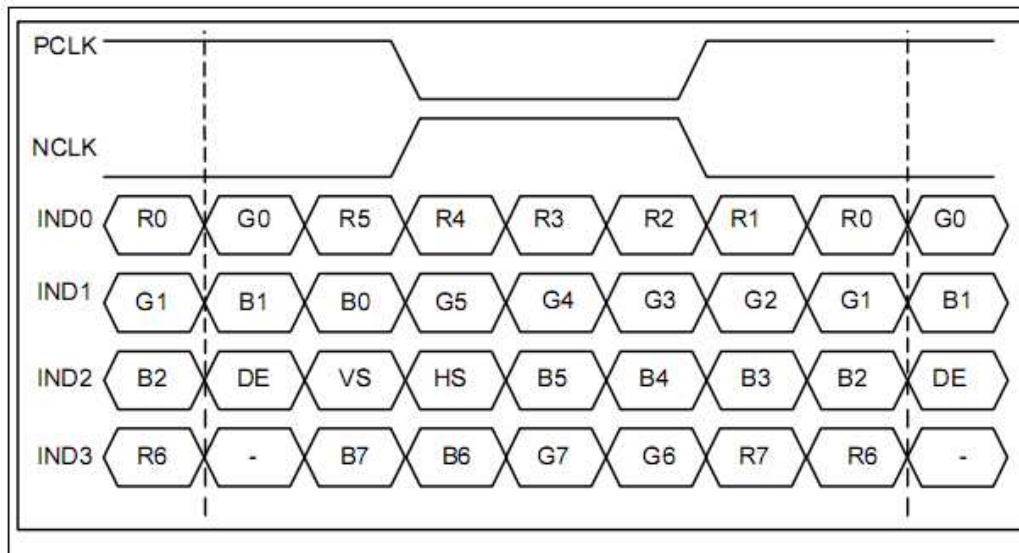

Document Title	HSD070PFW3-A Preliminary Specification	Page No.	17/25
Document No.	DC110-000851	Revision	2.0

6.4 Power On / Off Sequence

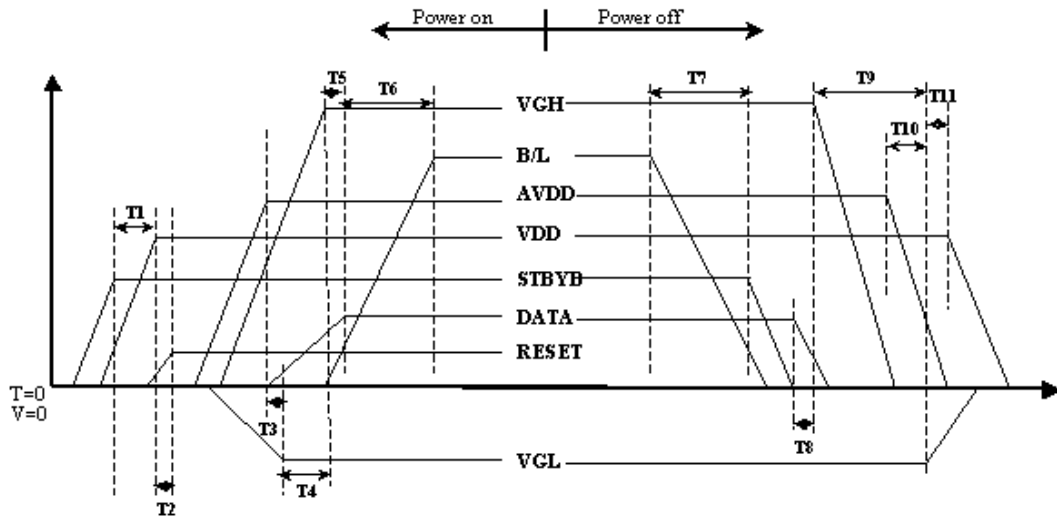

Item	Min.	Typ.	Max.	Unit
T1	0	--	--	ms
T2	50	--	--	ms
T3	5	--	--	ms
T4	10	--	--	ms
T5	20	--	--	ms
T6	50	--	--	ms
T7	20	--	--	ms
T8	10	--	--	ms
T9	20	--	--	ms
T10	10	--	--	ms
T11	20	--	--	ms

Document Title	HSD070PFW3-A Preliminary Specification	Page No.	18/25
Document No.	DC110-000851	Revision	2.0

6.5 Backlight Unit

Parameter	Symbol	Min	Typ	Max	Units	Condition
LED Current	I_F	--	120	--	mA	$T_a=25^\circ\text{C}$
LED Voltage	V_F	--	10.5	--	Volt	$T_a=25^\circ\text{C}$
LED Life-Time	N/A	10,000	--	--	Hour	$T_a=25^\circ\text{C}$ $I_F=20\text{mA}$ Note (2)

Note (1) LED life time (Hr) can be defined as the time in which it continues to operate under the condition: $T_a=25\pm 3^\circ\text{C}$, typical IL value indicated in the above table until the brightness becomes less than 50%.

Note (2) The "LED life time" is defined as the module brightness decrease to 50% original brightness at $T_a=25^\circ\text{C}$ and $I_L=120\text{mA}$. The LED lifetime could be decreased if operating I_L is larger than 120mA. The constant current driving method is suggested.

Note(3) LED Light Bar Circuit

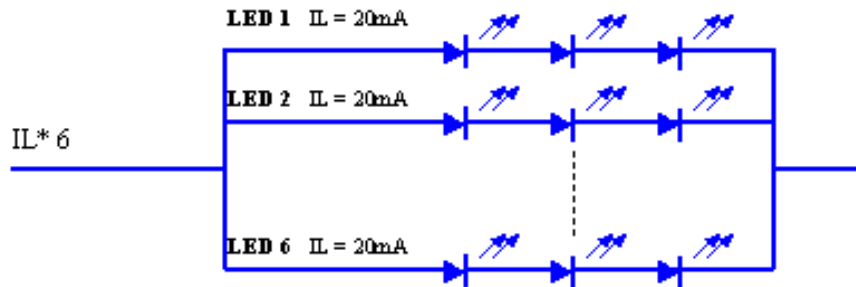

Document Title	HSD070PFW3-A Preliminary Specification	Page No.	19/25
Document No.	DC110-000851	Revision	2.0

7.0 Reliability test items

No.	Item	Conditions	Remark
1	High Temperature Storage	Ta=+70°C, 240hrs	
2	Low Temperature Storage	Ta=-30°C, 240hrs	
3	High Temperature Operation	Ta=+60°C, 240hrs	
4	Low Temperature Operation	Ta=-20°C, 240hrs	
5	Thermal Cycling Test (non operation)	-20°C(30min)→+60°C(30min),100 cycles	
6	Vibration	Sine Wave 1.5G, 5~500Hz, XYZ 30min/each direction	
7	Shock	Half-Sine, 200G, 2ms, ±XYZ, 1time	

Storage / Operating temperature

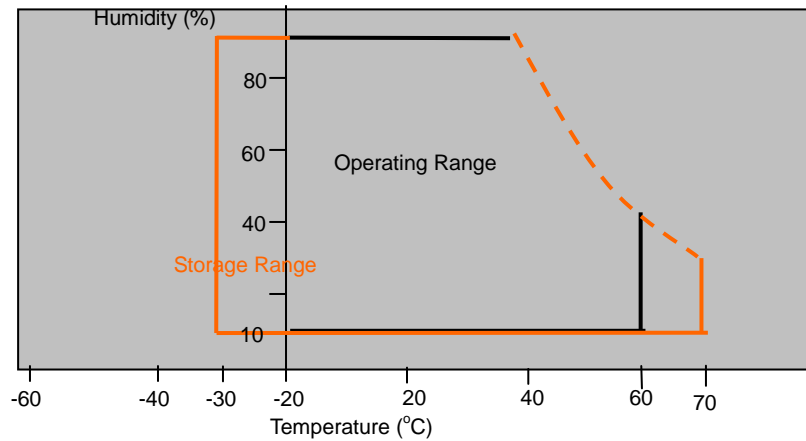

Note .Max wet bulb temp.=39°C

Document Title	HSD070PFW3-A Preliminary Specification	Page No.	20/25
Document No.	DC110-000851	Revision	2.0

8.0 OUTLINE DIMENSION

8.0 Front View Outline Dimension

Unit : mm

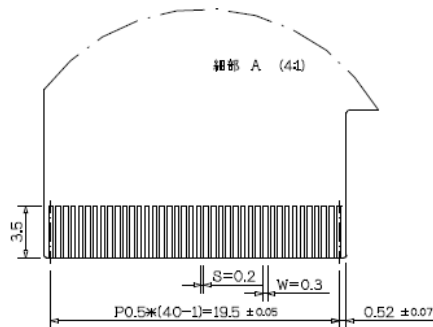
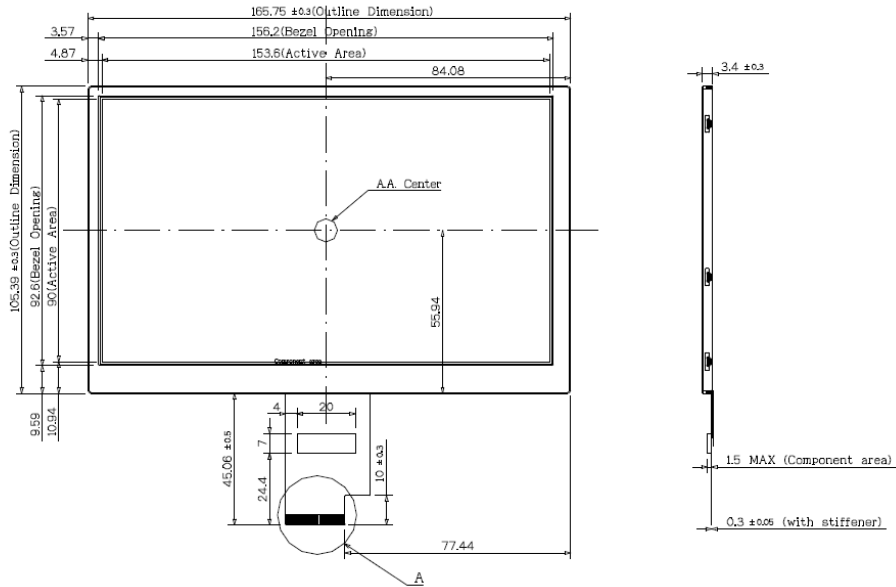

Document Title	HSD070PFW3-A Preliminary Specification	Page No.	21/25
Document No.	DC110-000851	Revision	2.0

8.1 Front View Outline Dimension

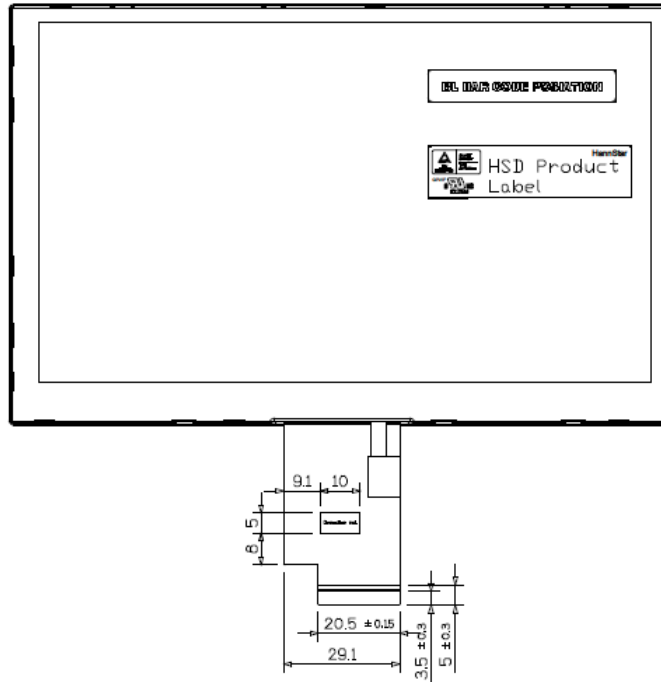

後視圖 (1/1)

Note:
General Tolerance $\pm 0.3\text{mm}$

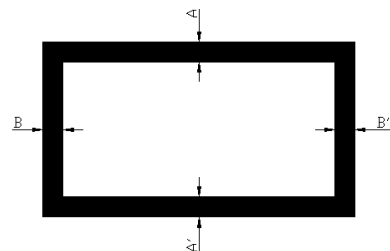

BM Assembly Tolerance-
 $|A - A'| \leq 1 \text{ (mm)}$
 $|B - B'| \leq 1 \text{ (mm)}$

Document Title	HSD070PFW3-A Preliminary Specification	Page No.	22/25
Document No.	DC110-000851	Revision	2.0

9.0 LOT MARK

9.1 Lot Mark

1	2	3	4	5	6	7	8	9	10	11	12	13	14	15	16	17
---	---	---	---	---	---	---	---	---	----	----	----	----	----	----	----	----

Code 1,2,3,4,5,6: HannStar internal flow control code.

Code 7: production location.

Code 8: production year.

Code 9: production month.

Code 10,11,12,13,14,15: serial number.

Code 16,17: rank

Note (1) Production Year

Year	2006	2007	2008	2009	2010	2011	2012	2013	2014	2015
Mark	6	7	8	9	0	1	2	3	4	5

Note (2) Production Month

Month	Jan.	Feb.	Mar.	Apr.	May.	Jun.	Jul.	Aug.	Sep.	Oct.	Nov.	Dec.
Mark	1	2	3	4	5	6	7	8	9	A	B	C

9.2 Location of Lot Mark

- (1) Location : The lot mark is printed to the back side of the LCD module. See Product back view. (Section 8.0 : OUTLINE DIMENSION)
- (2) Detail of the Lot mark: Print 15 code as lot mark (see 9.1 Lot Mark)
- (3) This is subject to change without prior notice.
- (4) Label mark: The label is attached to the front side of the LCD module



Document Title	HSD070PFW3-A Preliminary Specification	Page No.	23/25
Document No.	DC110-000851	Revision	2.0

10.0 PACKAGE SPECIFICATION

9.1 Packing form

LCM Model	LCM Qty. in the box	Inner Box Size (mm)	Notice
HSD070PFW3-A**	80pcs/box	451mmx375mmx284mm	

9.2 Packing assembly drawings

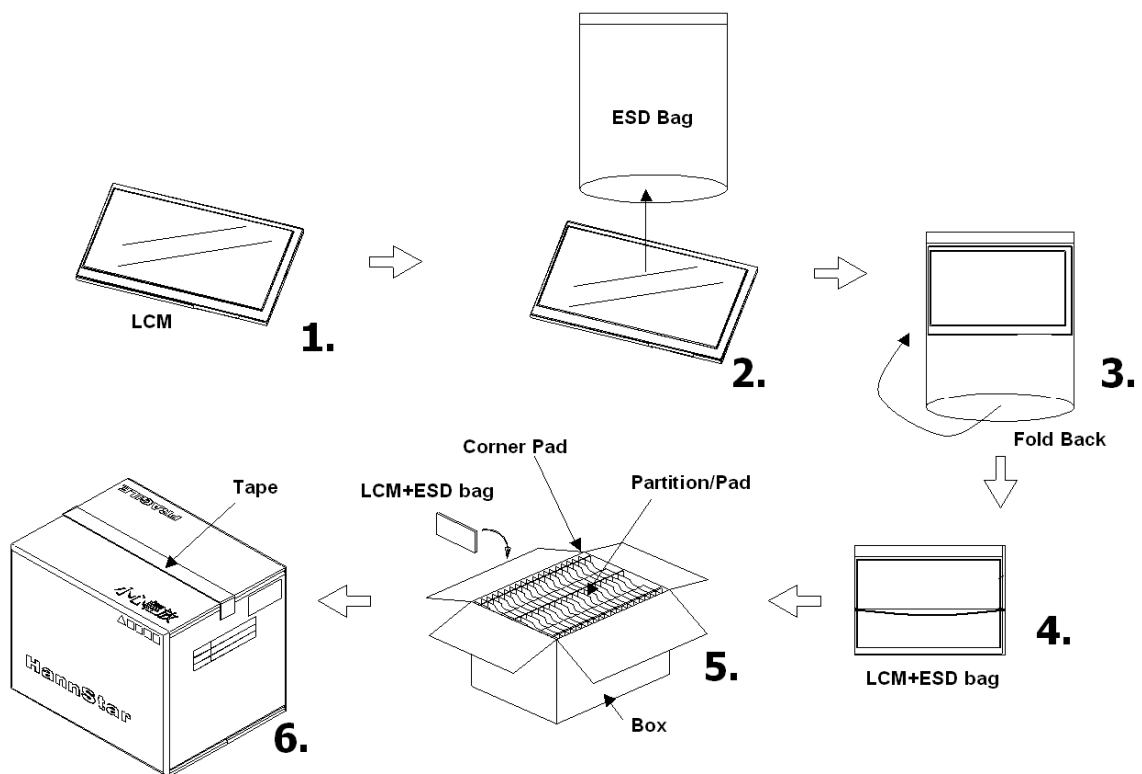

	Material	Notice
Box	Corrugated Paper Board	(AB Flute)
Partition/Pad	Corrugated Paper Board	(B Flute)
Corner Pad	Corrugated Paper Board	(AB Flute)
ESD bag	PE	

Document Title	HSD070PFW3-A Preliminary Specification	Page No.	24/25
Document No.	DC110-000851	Revision	2.0

11.0 GENERAL PRECAUTION

11.1 Use Restriction

This product is not authorized for use in life supporting systems, aircraft navigation control systems, military systems and any other application where performance failure could be life-threatening or otherwise catastrophic.

11.2 Disassembling or Modification

Do not disassemble or modify the module. It may damage sensitive parts inside LCD module, and may cause scratches or dust on the display. HannStar does not warrant the module, if customers disassemble or modify the module.

11.3 Breakage of LCD Panel

11.3.1. If LCD panel is broken and liquid crystal spills out, do not ingest or inhale liquid crystal, and do not contact liquid crystal with skin.

11.3.2. If liquid crystal contacts mouth or eyes, rinse out with water immediately.

11.3.3. If liquid crystal contacts skin or cloths, wash it off immediately with alcohol and rinse thoroughly with water.

11.3.4. Handle carefully with chips of glass that may cause injury, when the glass is broken.

11.4 Electric Shock

11.4.1. Disconnect power supply before handling LCD module.

11.4.2. Do not pull or fold the LED cable.

11.4.3. Do not touch the parts inside LCD modules and the fluorescent LED's connector or cables in order to prevent electric shock.

11.5 Absolute Maximum Ratings and Power Protection Circuit

11.5.1. Do not exceed the absolute maximum rating values, such as the supply voltage variation, input voltage variation, variation in parts' parameters, environmental temperature, etc., otherwise LCD module may be damaged.

11.5.2. Please do not leave LCD module in the environment of high humidity and high temperature for a long time.

11.5.3. It's recommended to employ protection circuit for power supply.

11.6 Operation

11.6.1 Do not touch, push or rub the polarizer with anything harder than HB pencil lead.

11.6.2 Use fingerstalls of soft gloves in order to keep clean display quality, when persons handle the LCD module for incoming inspection or assembly.

11.6.3 When the surface is dusty, please wipe gently with absorbent cotton or other soft material.

 HannStar Display Corp.			
Document Title	HSD070PFW3-A Preliminary Specification	Page No.	25/25
Document No.	DC110-000851	Revision	2.0

11.6.4 Wipe off saliva or water drops as soon as possible. If saliva or water drops contact with polarizer for a long time, they may causes deformation or color fading.

11.6.5 When cleaning the adhesives, please use absorbent cotton wetted with a little petroleum benzine or other adequate solvent.

11.7 Mechanism

Please mount LCD module by using mounting holes arranged in four corners tightly.

11.8 Static Electricity

11.8.1 Protection film must remove very slowly from the surface of LCD module to prevent from electrostatic occurrence.

11.8.2 Because LCD module use CMOS-IC on circuit board and TFT-LCD panel, it is very weak to electrostatic discharge. Please be careful with electrostatic discharge. Persons who handle the module should be grounded through adequate methods.

11.9 Strong Light Exposure

The module shall not be exposed under strong light such as direct sunlight. Otherwise, display characteristics may be changed.

11.10 Disposal

When disposing LCD module, obey the local environmental regulations.